

TRANSDUCER of TEMPERATURE and STANDARD SIGNALS P20 TYPE

NEW



APPLICATION

The P20 programmable transducer is destined to convert the temperature, resistance, voltage from shunt and standard signals into a standard constant-current or constant-voltage signal. The output standard signal is galvanically isolated from the input signal and the supply.

The transducer is fully configurable through the PD14 programmer. By means of the programmer one can change the input type, the averaging time of the measurement and rescale the analog output acc. to the individual output characteristic, and also read out the measured value.

TECHNICAL DATA

Basic parameters:

- analog output galvanically isolated:	
- current	0/4... 20 mA
- voltage	0...10 V
- load resistance of the current output	$\leq 500 \Omega$
- load resistance of the voltage output	$\geq 500 \Omega$
- accuracy class ¹⁾	0.2
- time of measurement averaging	≥ 0.3 s
- power consumption	< 3 VA
- preheating time of the transducer	10 min
- response time of the transducer	≤ 2 s
- current flowing through RTD	< 0.2 mA

Nominal operating conditions:

- supply depending on the execution code	85... 253 V a.c./d.c. 20... 40 V a.c./d.c.
- frequency of the supply a.c. voltage	45... 65 Hz
- ambient temperature	- 20... <u>23</u> ...55°C
- related air humidity	< 95% (condensation inadmissible)
- working position	any
- fastness to supply decays	acc. to EN 61000-6-2

Input parameters:

- resistance of voltage input [V]	> 1 M Ω
- resistance of current input [mA]	12 $\Omega \pm 1\%$

Sustained overload:

- TC and RTD	- 25...+85°C
- voltage, current and resistance	1.1 X _n 1.3 X _n

Short duration overload:

- input voltage	5 U _n
- current input	10 I _n

Ensured protection level acc. to EN 60529:

- housing	IP 40
- electrical connections	IP 20

Weight

0.125 kg

Dimensions

22.5 × 120 × 100 mm

Fitting

on a 35 mm rail holder

Electromagnetic compatibility:

- immunity to electromagnetic interference	acc. to EN 61000-6-2
- emission to electromagnetic interference	acc. to EN 61000-6-4

Safety requirements acc. to EN 61010-1:

● installation category	III,
● level of pollution	2,
● working voltages in relation to the ground:	
- supply	300 V ²⁾
- input	50 V
- output	50 V
● altitude above sea level	< 2000 m

¹⁾ Apart of sub-ranges for thermocouples has a definite individual class -see table 1

²⁾ Execution for supply voltage 230 V

DIAGRAMS OF EXTERNAL CONNECTIONS

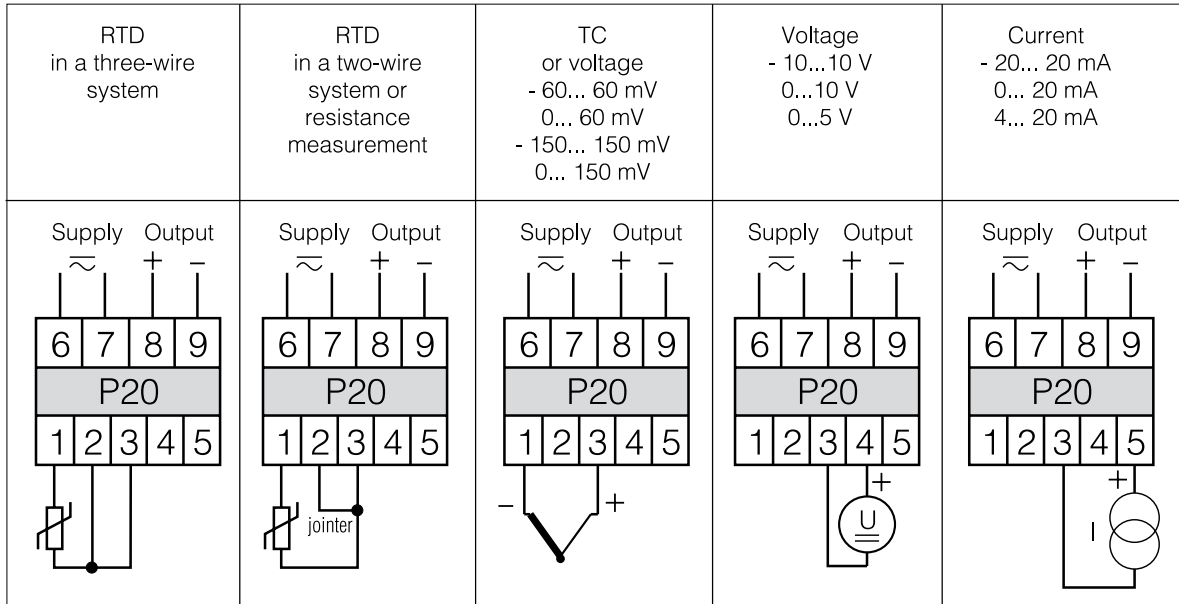

Coding of the P20 transducer input kind

Table 1

Type of sensor/input	Range [°C]	Code	Type of sensor/input	Range	Code
Pt100 RTD	-200...850	01	TC of K type	-200...1370	36
	0...850	02		0...1200	37
	0...600	03		0...1000	38
	0...400	04		0...800	39
	0...200	05		0...600	40
	-200...200	06		0...400*	41
	-100...100*	07		-200...200*	42
Pt250 RTD	-200...850	08	TC of S type	0...1760	43
	0...850	09		0...1600	44
	0...600	10		0...1400*	45
	0...400	11		0...1200*	46
	0...200	12	0...1000*	47	
	-200...200	13	TC of N type	-200...1200	48
	-100...100	14		0...1200	49
		0...1000		50	
Pt500 RTD	-200...850	15	0...800	51	
	0...850	16	0...600*	52	
	0...600	17	0...400*	53	
	0...400	18	-200...200*	54	
	0...200	19	d.c. voltage	0...10 V	55
	-200...200	20		0...5 V	56
	-100...100	21		-10...10 V	57
		-5...5 V		58	
Pt1000 RTD	-200...850	22	0...60 mV	59	
	0...850	23	-60...60 mV	60	
	0...600	24	-0...150 mV	61	
	0...400	25	-150...150 mV	62	
	0...200	26	d.c. current	0...20 mA	63
	-200...200	27		4...20 mA	64
	-100...100	28		0...5 mA	65
		-20...20 mA		66	
TC of J type	-200...1200	29	Resistance	0...400 Ω	67
	0...1200	30		0...4000 Ω	68
	0...1000	31	Custom-made		XX
	0...800	32			
	0...600	33			
	0...400*	34			
	-200...200*	35			

* accuracy class 0,5

EXECUTION CODES

TRANSDUCER	P20 -	X	X	XX	XX	X
Analog outputs:						
current 0... 20 mA.....						1
current 4... 20 mA.....						2
voltage 0... 10 V.....						3
Supply:						
85...253 V a.c./d.c.....						1
20...40 V a.c./d.c.....						2
Kind of input:						
write the code from table 1.....						XX
Execution:						
standard.....						00
custom-made*.....						XX
Acceptance tests:						
without additional requirements.....						8
with an extra quality inspection certificate.....						7
acc. to customer's requirements*.....						X

* after agreeing with the producer

EXAMPLE OF ORDER:

When ordering, please respect successive code numbers.

The code **P20 - 1 1 04 00 7** means:

P20 - transducer of temperature and standard signals

1 - with current analog output: 0... 20 mA

1 - voltage supply 85... 253 V a.c./d.c.

04 - Pt100 output signal on the 0...400°C range

00 - standard execution

7 - with an extra quality inspection certificate