

POWER TRANSDUCERS FOR SINGLE-PHASE AND THREE-PHASE NETWORK P11P, P13P, P13B



APPLICATION

The P11P transducer is destined for the conversion of active or reactive a.c. power into a d.c. current or d.c. voltage standard signal.

The input, output and supply circuits are galvanically isolated (transformer separation). The conversion frequency range enables the correct measurement of power when currents and voltages are distorted (up to 25 th harmonic). The pulse feeder ensures the operation in a width range of values and frequency of the supply voltage.

The measurement is realized through the analogue multiplier function with the pulse modulation (TDM). These transducers are destined to operate in industrial conditions and can be mounted in optional position.

Transducer housings are made of a self-extinguishing plastic and are adapted to be fixed on a 35 mm DIN rail (EN 60715).

P11P - transducer destined for active power measurement in a single-phase network.

P13P - transducer destined for active power measurement in a symmetrically loaded 3-phase 3-wire network.

P13B - transducer destined for reactive power measurement in a symmetrically loaded 3-phase 3-wire network.

TRANSDUCER SET

The transducer set includes:

- P11P or P13P or P13B transducer 1 pc
- service manual 1 pc
- guarantee card 1 pc

INSTALLATION

The P11P or P13P or P13B transducer is designed to be installed on a 35 mm DIN rail acc. EN 60715. On the external side of the transducer there are screw or self-locking terminal strips enabling the connection of 2.5 mm² external leads (supply and output) up to 1.5 mm² leads (input).

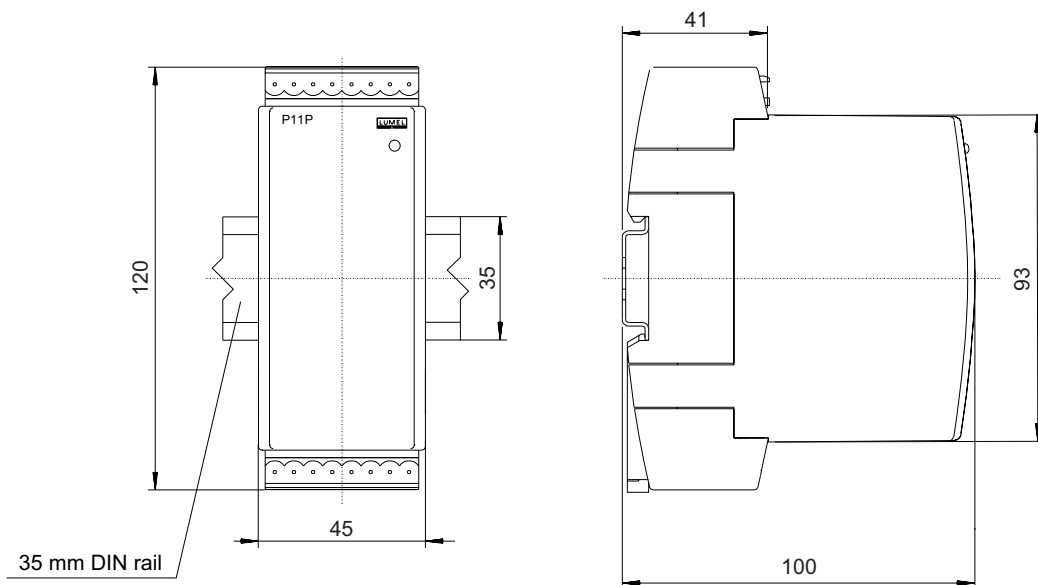
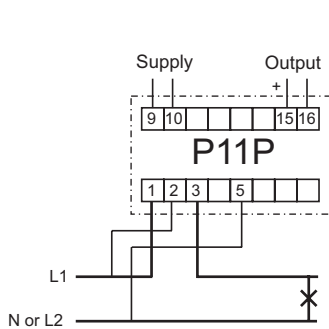

Fig.1 Overall dimensions and fixing way of the transducer

DIAGRAMS OF EXTERNAL CONNECTIONS

The P11P or P134P or P13B transducer has two sockets of terminal strips and two connectors are included, a screw plug or a self-locking plug, depending on the chosen type by the user in the order code.

Measurement of active power in a single-phase network by a P11P transducer.



a) Direct measurement of single-phase active power

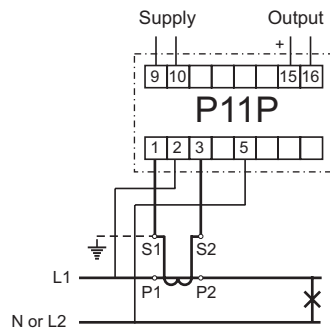

b) Measurement of single-phase active power through a current transformer

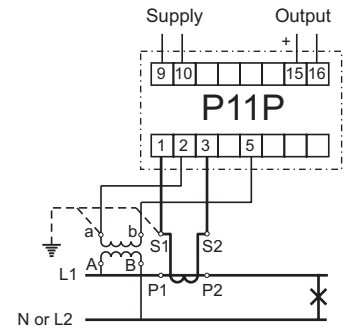

c) Measurement of single-phase active power through a current and voltage transformer

Measurement of active power in a 3-phase 3-wire network by a P13P transducer (Symmetrically loaded)

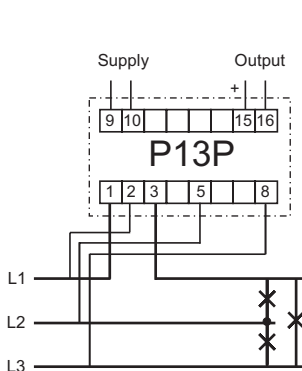

a) Direct measurement of active power in a 3-phase 3-wire network symmetrically loaded

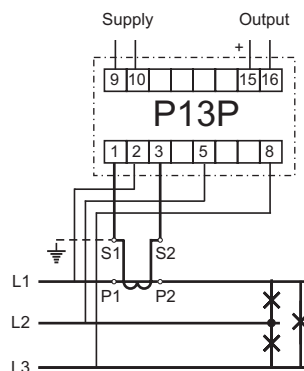

b) Measurement of active power in a 3-phase 3-wire network symmetrically loaded through a current transformer

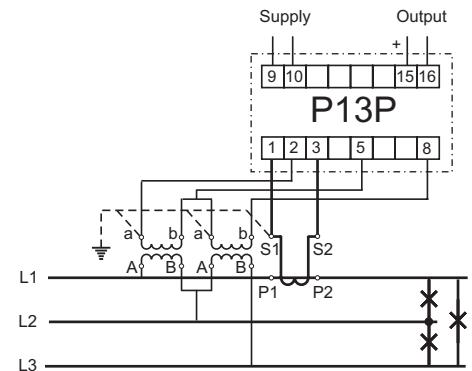

c) Measurement of active power in a 3-phase 3-wire network symmetrically loaded through a current and a voltage transformer

Measurement of reactive power in a 3-phase 3-wire network by a P13B transducer (Symmetrically loaded)

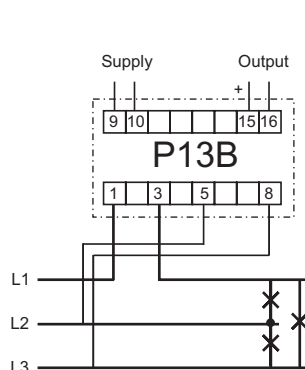

a) Direct measurement of reactive power in a 3-phase 3-wire network symmetrically loaded

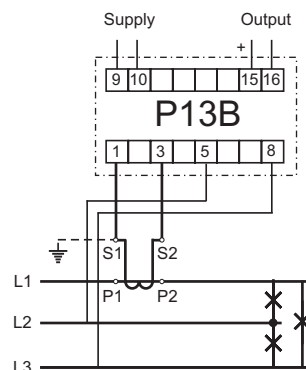

b) Measurement of reactive power in a 3-phase 3-wire network symmetrically loaded through a current transformer

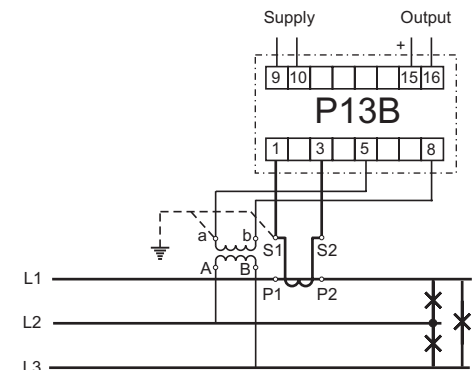

c) Measurement of reactive power in a 3-phase 3-wire network symmetrically loaded through a current and a voltage transformer

TECHNICAL DATA

Basic parameters:

- input current	1 A (X/1 A), 5 A (X/5 A)
- input voltage	10/√3 V, 100 V, 230 V, 400 V, 500 V, 690 V, X/100 V
- output signals	5 mA, 20 mA, 4...20 mA, 10 V
- accuracy class	0.5
- output load resistance:	
- for 5 mA current output	0...2000 Ω
- for 20 mA current output	0...500 Ω
- for 10 V voltage output	≥ 500 Ω
- circuit consumption:	
- voltage measurement	≤ 0.6 VA
- current measurement	≤ 0.3 VA
- supply	≤ 6 VA
- preheating time of the transducer	15 min.
- set-up time of the output signal (0/90%)	≤ 0.5 s
- insulation test voltage	3.25 kV
- limitation of output current	28 mA ± 10%

Nominal reference and operating conditions:

- ambient temperature	-20...23...55°C
- supply voltage	18...40 V or 85...253 V a.c./d.c.
- frequency of the supply voltage	40...400 Hz
- frequency of the input current (voltage)	45...65...1250 Hz
- input voltage	0...0.01...1.2 Un
- power factor (cosφ)	-1...0...1
- input current	0...0.01...1.2 In
- peak factor of the measured current	≤ 3
- peak factor of the measured voltage	≤ 2
- storage temperature	-25...+85°C
- relative humidity (condensation inadmissible)	0...45...75
- external magnetic field	0...40...400 A/m
- working position	optional.

Additional Errors caused by the influence of:

- frequency of the input quantity	< 0.05 × acc. class/100 Hz
- ambient temperature	< 0.5 × acc. class/10°C
- external magnetic field	< 0.1 × acc. class/100 A/m.

Input overload:

Voltage:

- short duration	2·Un
- long-lasting	1.2·Un

Current:

- short duration	10·In
- long-lasting	1.2·In

Ensured protection degree:

- by the housing	IP50
- from the terminal side	IP20

Dimensions 45 x 100 x 120 mm

Weight 210 g

Compliance to standards:

- service security, requirements and tests	EN 61010-1
- insulation ensured by the housing	double
- insulation between circuits	basic
- installation category	III
- pollution level	2
- maximal working voltage in relation to earth	600 V

Electromagnetic compatibility:

- immunity	EN 61000-6-2
- emission	EN 61000-6-4

ORDERING CODES

Ordering codes of P11P, P13P and P13B transducers Table 1

POWER TRANSDUCER - P1	XX	XX	XX	X	X	X	XX	X
Kind of transducer:								
measurement of 1-phase active or reactive power								
measurement of active power in 3-phase 3-wire systems, symmetric load								
measurement of reactive power in 3-phase 3-wire systems, symmetric load								
Input current:								
write down the range code (from A1 to Z1 and B5 to Z5) from the table 2:								
1 A								A1
20 000/1 A								Z1
5 A								B5
20 000/5 A								Z5
on order*								99
Input voltage:								
write down the range code (from A to V) from the table 2:								
100/√3 V								A
400 000/100 V								W
on order*								X
Output range:								
0...5 mA, R load = 0...2000 Ω								1
0...20 mA, R load = 0...500 Ω								2
4...20 mA, R load = 0...500 Ω								3
0...10 V, R load ≥ 500 Ω								4
-5...0...5 mA, R load = 0...2000 Ω								5
-20...0...20 mA, R load 0...500 Ω								6
-10...0...10 V, R load ≥ 500 Ω								7
on order*								9
Supply:								
85...253 V d.c. or a.c. (40...400 Hz)								1
18...40 V d.c. or a.c. (40...400 Hz)								2
on order*								9
Kind of terminals:								
permanent fastening screws								1
socket - screw plug								2
socket - self-locking plug								3
Version:								
standard								00
custom-made*								XX
Acceptance test:								
without a quality inspection certificate								0
with a quality inspection certificate								1
acc user's agreement**								X

* Custom-made version, one must agree with the producer

** The producer will settle the ordering code number

Coding example:

The **P11P-A1-C-1-1-1-00-0** code means:

the version of a transducer for measurement of active power in a single-phase system, input: In = 1 A, Un = 230 V, nominal power: 200 W, permanent fastening screw terminals, standard version, without a quality inspection certificate.

Table 2

Un [V]	Measurement of single-phase active power					Measurement of 3-phase 3-wire active or reactive power in a symmetrically loaded network																		
	1P	$\frac{100}{\sqrt{3}}$	100	230	400	500	400	500	690	$\frac{3\ 000}{100}$	$\frac{6\ 000}{100}$	$\frac{10\ 000}{100}$	$\frac{15\ 000}{100}$	$\frac{20\ 000}{100}$	$\frac{30\ 000}{100}$	$\frac{40\ 000}{100}$	$\frac{60\ 000}{100}$	$\frac{110\ 000}{100}$	$\frac{220\ 000}{100}$	$\frac{400\ 000}{100}$				
In/x	In code		Power unit	Un code																				
	x=5	x=1		A	B	C	D	E	G	H	I	K	L	M	N	P	R	S	T	U	V	W		
1	-	A1	W	50	100	200	400	500	600	800	1	5	10	15	25	30	50	60	100	150	300	600		
5; 5/x	B5	B1		250	500	1	2	2.5	3	4	5	25	50	80	120	150	250	300	500	800	1.5	3		
10/x	C5	C1		500	1	2	4	5	6	8	10	50	100	150	250	300	500	600	1	1.5	3	6		
15/x	D5	D1		800	1.5	3	6	7.5	10	12	15	75	150	250	300	500	750	1	1.5	2.5	5	10		
20/x	E5	E1		KW; kvar	1	2	4	7.5	10	12	15	20	100	200	300	500	600	1	1.2	2	3	7.5	12	
30/x	F5	F1			1.5	3	6	12	15	20	25	30	150	300	500	750	1	1.5	2	3	5	10	20	
50/x	G5	G1			2.5	5	10	20	25	30	40	50	250	500	800	1.2	1.5	2.5	3	5	8	15	30	
75/x	H5	H1			4	7.5	15	30	30	50	60	80	300	750	1.2	1.5	2.5	3	5	7.5	12	25	50	
100/x	I5	I1			5	10	20	40	50	60	80	100	500	1	1.5	2.5	3	5	6	10	15	30	60	
150/x	J5	J1			8	15	30	60	75	100	120	150	750	1.5	2.5	3	5	7.5	10	15	25	50	100	
200/x	K5	K1			10	20	40	80	100	120	150	200	1	2	3	5	6	10	12	20	30	75	120	
300/x	L5	L1			15	30	60	120	150	200	250	300	1.5	3	5	7.5	10	15	20	30	50	100	200	
400/x	M5	M1			20	40	80	150	200	250	300	400	2	4	6	10	12	20	25	40	75	150	250	
600/x	N5	N1			30	60	120	200	300	400	500	600	3	6	10	12	20	25	40	60	100	200	400	
800/x	P5	P1			40	80	150	300	400	500	600	800	4	8	12	20	25	40	50	80	150	300	500	
1000/x	R5	R1			50	100	200	400	500	600	800	1	5	10	15	25	30	50	60	100	150	300	600	
1200/x	S5	S1			60	120	250	400	800	800	1	1.2	6	12	20	30	40	60	80	120	200	400	800	
1500/x	T5	T1			80	150	300	600	750	1	1.2	1.5	7.5	15	25	30	50	75	100	150	250	500	1000	
2000/x	U5	U1			100	200	400	800	1	1.2	1.5	2	10	20	30	50	60	100	120	200	300	750		
3000/x	V5	V1	150		300	600	1.2	1.5	2	2.5	3	15	30	50	75	100	150	200	300	300	1000			
4000/x	W5	W1	200		400	800	1.5	2	2.5	3	4	20	40	60	100	120	200	250	400	750				
6000/x	X5	X1	300		600	1.2	2	3	4	5	6	30	60	100	150	200	300	400	600	1000				
10000/x	Y5	Y1	500		1	2	4	5	6	8	10	50	100	150	200	300	400	600	1000					
20000/x	Z5	Z1	MW; Mvar	1	2	4	8	10	12	15	20	100	200	300	500	600	1000	1200						

HISPACONTROL S.L.
 Paseo Delicias 65 Bis, 28045 Madrid
 Tel. 915.308.552
 Fax. 914.673.170
 Email. hc@hispacontrol.com
 Web. www.hispacontrol.com