

# Thermowells

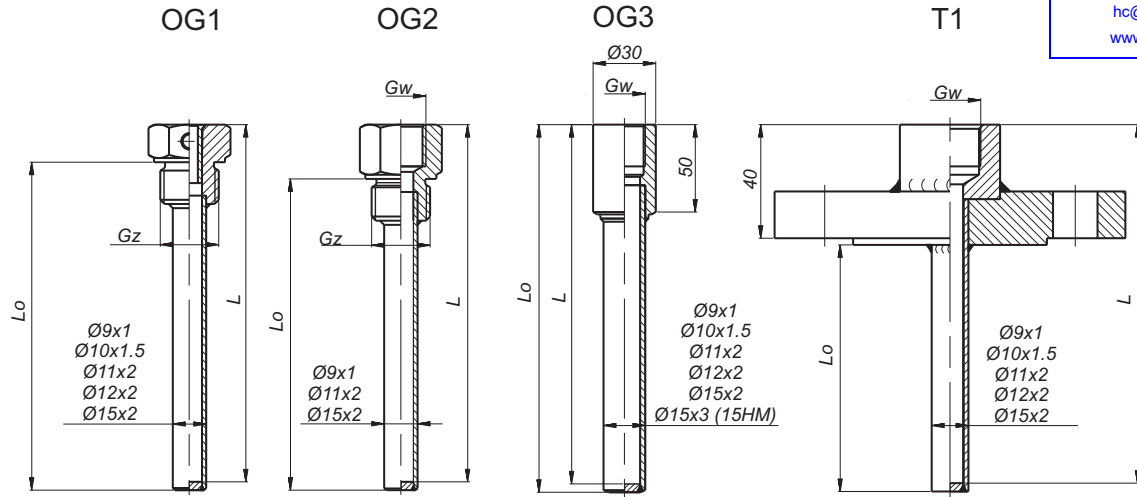

Material: ØG1, ØG2 - 1.4301, 1.4541, 1.4404; ØG3 - 1.7335 (13CrMo4-5, 15HM)

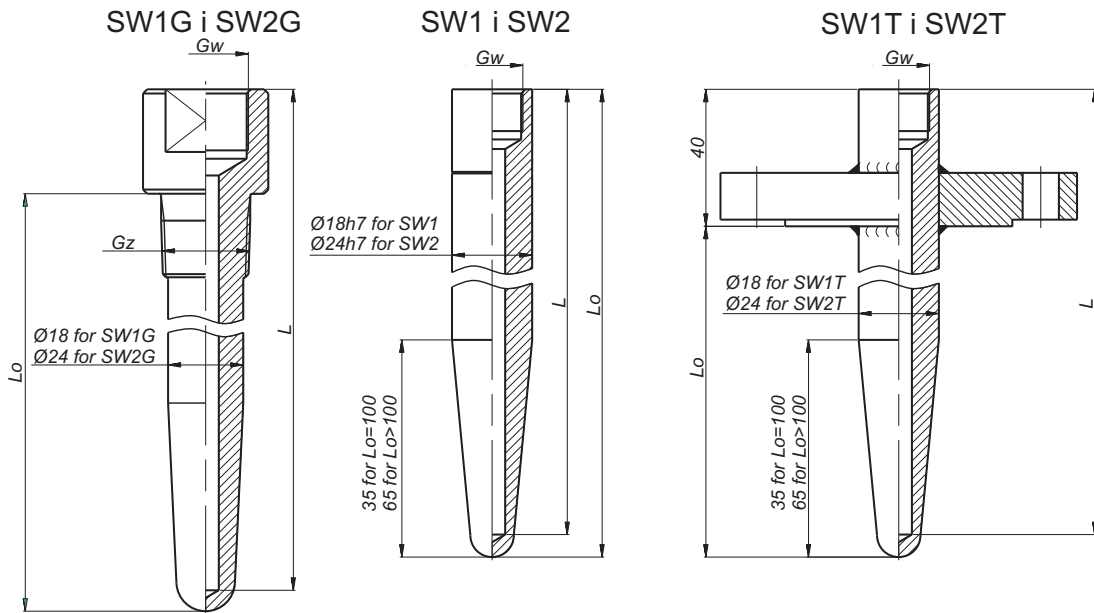

Material: 1.4301, 1.4541, 1.4404, 1.7335 (13CrMo4-5, 15HM), 1.7380 (10CrMo9-10, 10H2M)

Ordering procedure with example of ordering code:

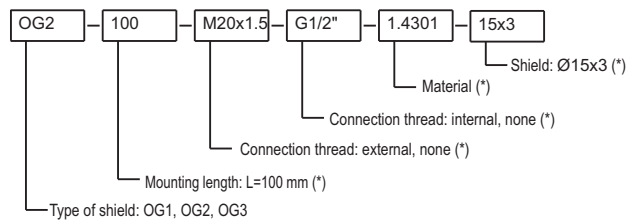

## ADMISSIBLE LOADS FOR PARTICULAR TYPES OF SHIELDS AT SPECIFIED WORKING CONDITIONS

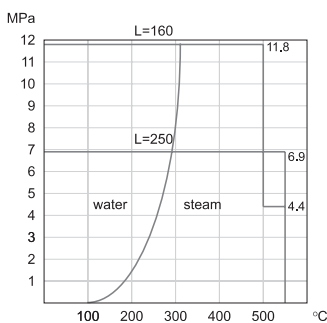

Graph 1. Admissible load of the G1 and T1 shields at the conditions of work - 15HM, 1H18N9T, H17N13M2T

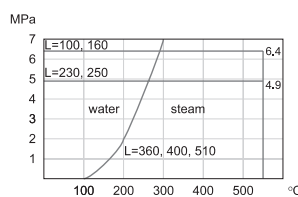

Graph 2. Admissible load of the GN1 and GB1 shields at the conditions of work - 15HM, 1H18N9T, H17N13M2T

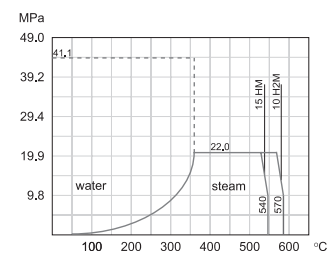

Graph 3. Admissible load of the SW1 and SW2 shields at the conditions of work