

### RADAR LEVEL METERS WITH GUIDED WAVE (PRINCIPLE TDR)

- Suited to continuous level measurement of various liquid, bulk solids, mush and pasty materials.
- Quick view measured values on the display
- Universal use, direct mounting into hoppers, silos, tanks, sumps etc.
- Variants with stainless steel rod or rope electrode
- Measuring range up to 40m
- Possibility of using in explosive areas (version Xi, XiT), or in flammable dust areas (Xd, XdT)
- Current output (4 ... 20 mA), HART® protocol

The GRLM® radar level meters are compact measurement devices including an transmitter of microwave pulses, central processor unit and display module. The electronics transmits very short electrical pulses (0.5 ns), which are linked to a one-wire transmission line (measuring electrode). Measuring electrode can be created of rod or rope. The pulse propagates along the electrode in the form of electromagnetic wave toward the level surface, where it is partly reflected and the reflected component is returned to the receiving module of the electronics. The electronics measures the time of flight of electromagnetic wave and the instant distance to the surface level is calculated. According to the level height, the level meter output is set and the measured value is displayed on the display.

Radar level meters are resistant against changes in the atmosphere (pressure, temperature, dust, steam) and to changes in medium parameters (change in dielectric constant, conductivity).



### VARIANTS OF SENSORS

- |                    |   |
|--------------------|---|
| <b>GRLM-70_-00</b> | <b>without electrode</b> , the electrode is made by customer (only variant 10 or 30) and connected to the electrode junction by M8 thread.  |
| <b>GRLM-70_-10</b> | <b>Uncoated stainless steel rod electrode</b> , for level measurement liquids and bulk solid materials (water, water solutions, emulsion, oils, diesel, flour, sand, granulates, etc.). Maximum electrode length 8 m.                 |
| <b>GRLM-70_-11</b> | <b>Fully coated stainless steel rod electrode (PFA Teflon®)</b> , for level measurement of aggressive liquids and very pure liquids. Maximum electrode length 2 m.  |
| <b>GRLM-70_-12</b> | <b>Fully coated stainless steel rod electrode (FEP Teflon®)</b> , for level measurement of aggressive liquids and drinks. Maximum electrode length 2 m.   |
| <b>GRLM-70_-20</b> | <b>Uncoated stainless steel rod electrode with reference tube</b> , for accurate level measurement of liquids in cramped spaces. Maximum electrode length 3 m.  |
| <b>GRLM-70_-30</b> | <b>Uncoated stainless steel rope electrode and weight</b> , for level measurement of liquids and bulk solid materials (water, grains, sand, flour, cement, etc.) in higher silos, vessels, reservoirs. Maximum electrode length 40 m. |
| <b>GRLM-70_-32</b> | <b>Fully coated stainless steel rope electrode (FEP Teflon®) and coated weight (PTFE)</b> , for level measurement of aggressive liquids and very pure liquids. Maximum electrode length 12 m.   |
| <b>GRLM-70_-33</b> | <b>Uncoated stainless steel rope electrode with anchorage</b> , for level measurement of bulk solid materials (grains, flour, cement, etc.) in higher silos, vessels. Maximum electrode length 40 m.                                  |

**GRLM-70\_-34**

**Coated stainless steel rope electrode (Polyamid) and uncoated weight, a**  
for level measurement of liquids and adhesive bulk solids (flour, cement, etc.). aaa  
Maximum electrode length 40 m.

**GRLM-70\_-35**

**Coated stainless steel rope electrode (Polyamid) with uncoated anchorage,**  
for level measurement of adhesive bulk solids (flour, cement, etc.). a  
Maximum electrode length 40 m.

## DIMENSIONAL DRAWINGS

**GRLM-70\_-00**

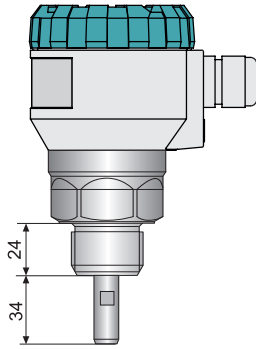

**variant GRLM-70  
with protective conductor**

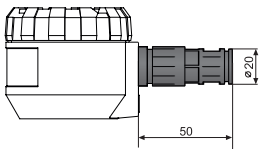

**GRLM-70\_-10(11,12)**

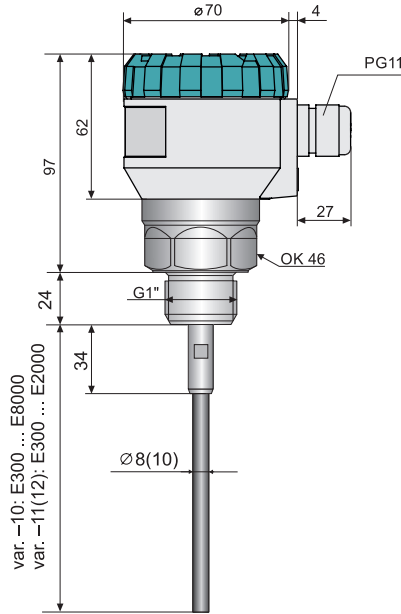

**GRLM-70\_-20**

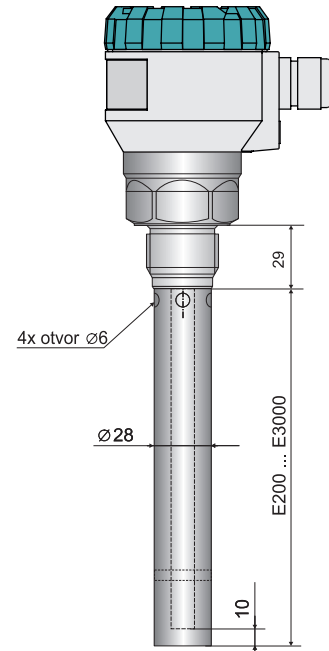

**GRLM-70\_-30(33,34,35)**

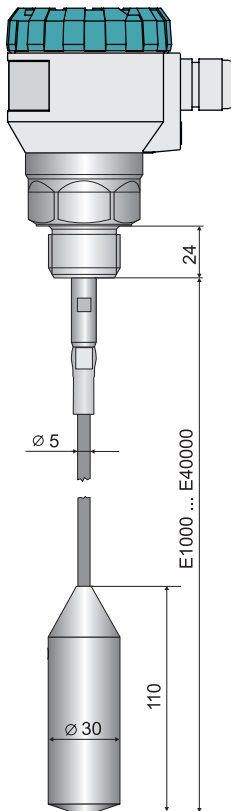

**Anchoring eye for variant  
GRLM-70\_-33 (35)**

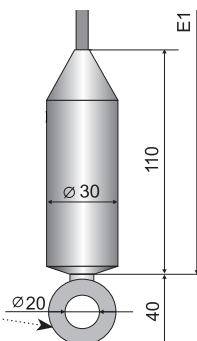

**GRLM-70\_-32**

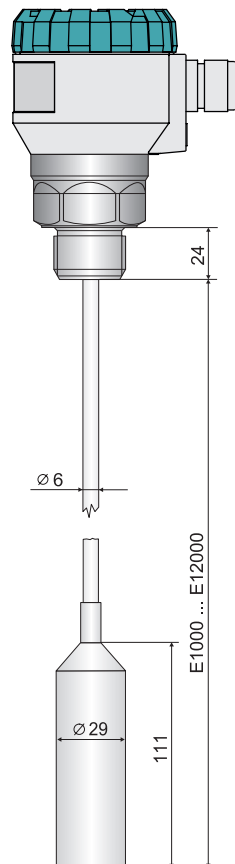

**High temperature variant  
GRLM-70\_T**

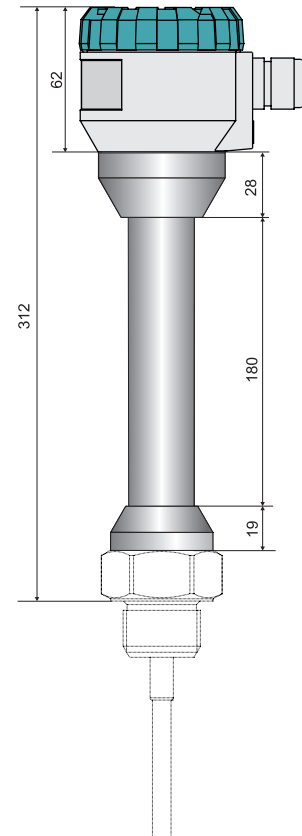

TECHNICAL SPECIFICATIONS – LEVEL METER		
Supply voltage	GRLM-70N-__ GRLM-70Xi-__ GRLM-70Xd-__	18 ... 36 V DC 18 ... 30 V DC 18 ... 36 V DC
Output		4 ... 20 mA, HART®
Current consumption		4 ... 20 mA / max. 22 mA
Basic error <sup>1)</sup> (for reference reflector) - GRLM-70__-20 in area 0,1 – 0,2 m / 0,2 – 2,0 m / 2,0 – 40 m .....- other types in area 0,1 – 0,2 m / 0,2 – 2,0 m / 2,0 – 40 m		± 5 mm / ± 3 mm / ± 2 mm ± 10 mm / ± 4 mm / ± 2 mm
Resolution		1 mm
Maximal length of measuring electrode	GRLM-70_-10 GRLM-70_-11 (12) GRLM-70_-20 GRLM-70_-30 (33, 34, 35) GRLM-70_-32	8 m 2 m 3 m 40 m 12 m
Dead zone <sup>2)</sup> - for measur. sensitivity - low, medium, user (1 - 4) - high, user (5) - user (6, 7) - user (8)		100 / 0 mm <sup>3)</sup> 150 / 50 mm <sup>3)</sup> 200 / 50 mm <sup>3)</sup> 250 / 50 mm <sup>3)</sup>
Electrical parameters for variants Xi (XiT) – max. internal values		U <sub>i</sub> =30 V DC; I <sub>i</sub> =132 mA; P=0,99W; C <sub>i</sub> =370 nF; L <sub>i</sub> =0,9 mH
Measurement sensitivity (8 degrees)		low (1) - medium (3) - high (5) - user (1 - 8)
Failure indication (echo loss, internal failure)		Adjustable in modes: 3,75 mA, 4 mA, 20 mA, 22 mA, LAST <sup>4)</sup>
Damping		1 .. 99 s
Warm up time		cca 60 s
Internal resistance / Electric strength (Electrode - Housing)		10 kΩ
Coupling capacity / Electric strength (Housing - Supply leads)		5 nF / 500 V AC
Maximal current output load resistance for	U = 24 V DC U = 22 V DC U = 20 V DC	R <sub>max</sub> = 270 Ω <sup>5)</sup> R <sub>max</sub> = 180 Ω R <sub>max</sub> = 90 Ω
Maximum tensile strength of the rope electrode		1400 kg
Protection class		IP67
Process connection		screwing with thread G1"
Recommended cable		PVC 2 x 0,75 mm <sup>2</sup>
Weight (without electrode)		cca 0,5 kg (1 kg variant NT, XiT)

1) Error is larger at the beginning and end of the rod or rope electrode. More detailed informations can be found in the instruction manual.

2) Dead zone = Blind zone = Blocking distance

3) The length of dead zone at the beginnig / at the end of the electrode. (The length of dead zone is 110 mm at the end of rope electrode.)

4) Level meter displays last measured value.

5) Including 250R resistor in case of HART connection.

TECHNICAL SPECIFICATIONS – DISPLAY MODUL	
Type of display	matrix OLED
Resolution	128 x 64 pixels
Height of digits / Number of display digits of measured values	9 mm / 5 digits
Colour of display	yellow
Type of buttons	membrane
Ambient temperature range	-30 ... +70 °C
Weight	46 g

## USED MATERIALS

Sensor part	Variants	Standard material
Lid	All types	aluminium with powder coating
Glass	All types	polycarbonate
Body	All types	aluminium with powder coating
Housing with thread	All types	St. Steel W. Nr. 1.4571 (AISI 316 Ti)
Electrode	GRLM-70_-10(11,20) GRLM-70_-12 GRLM-70_-30(32,33,34,35)	St. Steel W. Nr. 1.4571 (AISI 316 Ti) St. Steel W. Nr. 1.4301 (AISI 304) St. Steel W. Nr. 1.4404 (AISI 316 L)
Electrode coating	GRLM-70_-11 GRLM-70_-12 GRLM-70_-32 GRLM-70_-34, 35	PFA FEP FEP PA
Reference tube	GRLM-70_-20	St. Steel W. Nr. 1.4301 (AISI 304)
Weight	GRLM-70_-30	St. Steel W. Nr. 1.4301 (AISI 304)
Weight coating	GRLM-70_-32	PTFE
Anchorage	GRLM-70_-33	St. Steel W. Nr. 1.4301 (AISI 304)
Display module	All types	plastic material POM

## DEVICE CLASSIFICATION (according to EN 60079-10-1 and EN 60079-10-2)

GRLM-70N	Performance for non-explosive areas
GRLM-70NT	High temperature performance for non-Ex areas (max. 200°C)
GRLM-70Xi(XiT)	Performance for explosive areas (gases or vapour) ⊕ II 1/2 G Ex ia IIB T6 Ga/Gb with ISSU <sup>1)</sup> electrode part zone 0, housing zone 1
GRLM-70Xd(XdT)	Performance for flammable dust areas ⊕ II 1 D Ex ta IIIC T85°C...T300°C Da (current), ⊕ II 1 D Ex ta IIIC T100°C...T300°C Da (Modbus), whole level meter zone20

<sup>1)</sup>Intrinsically safe supply unit (for example: Dinel IRU-420).

## TEMPERATURE AND PRESSURE RESISTIVITY (performance N, Xi)

Variants / Performance	temperature $t_p$	temperature $t_m$	temperature $t_a$	Max. operation pressure for temp. $t_p$	
				to 30°C	to 85°C
GRLM-70_-10(20)	-40°C ... +85°C	-40°C ... +300°C	-30°C ... +70°C	15 MPa	10 MPa
GRIM-70_-11(12)	-40°C ... +85°C	-40°C ... +200°C	-30°C ... +70°C	4 MPa	2,5 MPa
GRLM-70_-30(33)	-40°C ... +85°C	-40°C ... +200°C	-30°C ... +70°C	15 MPa	10 MPa
GRLM-70_-32	-40°C ... +85°C	-40°C ... +130°C	-30°C ... +70°C	1 MPa	0,5 MPa
GRLM-70_-34(35)	-40°C ... +85°C	-40°C ... +95°C	-30°C ... +70°C	15 MPa	10 MPa

## TEMPERATURE RESISTIVITY (performance NT, XiT)

Variants / Performance	temperature $t_p$	temperature $t_m$	temperature $t_a$
GRLM-70_T-10(20)	-40°C ... +200°C	-40°C ... +300°C	-30°C ... +70°C
GRIM-70_T-11(12)	-40°C ... +200°C	-40°C ... +200°C	-30°C ... +70°C
GRLM-70_T-30(33)	-40°C ... +200°C	-40°C ... +200°C	-30°C ... +70°C
GRLM-70_T-32	-40°C ... +130°C	-40°C ... +130°C	-30°C ... +70°C
GRLM-70_T-34(35)	-40°C ... +130°C	-40°C ... +95°C	-30°C ... +70°C

Note: For correct function of the level meter must not be exceeded any of the temperature range ( $t_p$ ,  $t_m$  or  $t_a$ ).

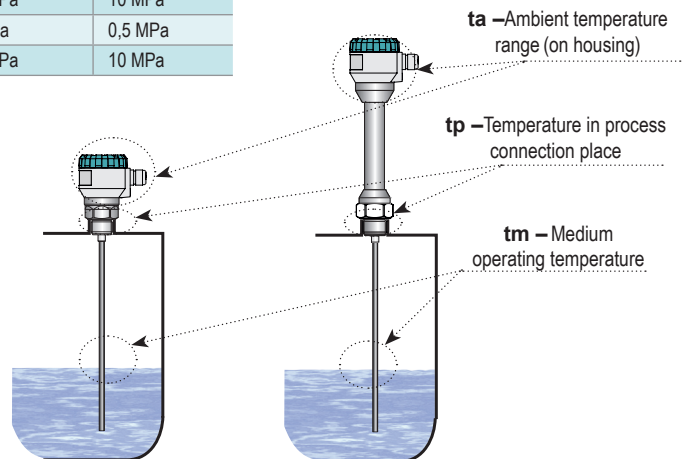

## PRESSURE RESISTIVITY (performance NT, XiT)

Variants / Performance	Max. operation pressure for temp. $t_p$				
	to 30°C	to 85°C	to 130°C	to 160°C	to 200°C
GRLM-70_T-10(20)	15 MPa	10 MPa	3 MPa	2 MPa	1 MPa
GRIM-70_T-11(12)	4 MPa	2,5 MPa	2 MPa	1,5 MPa	0,3 MPa
GRLM-70_T-30(33)	15 MPa	10 MPa	3 MPa	-	-
GRLM-70_T-32	1 MPa	0,5 MPa	0,1 MPa	-	-

## MAXIMAL TEMPERATURES FOR PERFORMANCE $X_i(XiT)$ CATEGORY 1/2G

temp. class	temperature $t_p$	temperature $t_m$	temperature $t_a$
T5	-40°C ... +90°C	-40°C ... +98°C	-30°C ... +70°C
T4	-40°C ... +125°C	-40°C ... +133°C	-30°C ... +70°C
T3	-40°C ... +190°C	-40°C ... +198°C	-30°C ... +70°C
T2	-40°C ... +200°C	-40°C ... +298°C	-30°C ... +70°C
T1	-40°C ... +200°C	-40°C ... +300°C	-30°C ... +70°C

## DEVICE SURFACE TEMPERATURE FOR PERFORMANCE $X_D(XDT)$ CATEGORY 1D

part of level meter	device surface temperature
electrode GRLM-70_--_I GRLM-70_--_M	medium temp. $t_m$ +5°C medium temp. $t_m$ +10°C
housing, electronic part GRLM-70_--_I  GRLM-70_--_M	temperature $t_p$ +15°C temperature $t_a$ +15°C temperature $t_p$ +30°C temperature $t_a$ +30°C

The maximum allowable temperature of the medium, process connection and ambient temperature depends in GRLM-70Xi (XiT) at the desired temperature class (see tab. Maximum temperatures for the performance  $X_i$  (XiT) category 1/2G and tab.). The temperature value can not be exceeded, because the hot surface of the device could cause ignition of an explosive or flammable atmosphere. At the same time can not exceed the maximum temperature for the different variants of the electrodes (Table of temperature durability).

## INSTALLATION

Install the level meter into the upper lid of the tank or reservoir using a **welding flange** or **fastening nut**.

The min. distance to install the level meter into a lid or a ceiling of a tank from the metal tank wall is 300 mm and from the non-metal tank wall is 500 mm (except GRLM-70\_-20).

If installed in an open channel (sumps, reservoirs, etc.), install the level meter as closest as you can to the maximum level expected.

Rope electrode level meter must untangle and then can be inserted into the tank.

In case any visible defects are discovered, the manufacturer or reseller of this equipment must be contacted immediately.

## INSTALLATION AND RECOMMENDATIONS

We recommend to keep the specified distances from the tank wall. Otherwise, the level meter install as far as possible from the walls, to the middle between the wall and the vertical inlet.

The minimum distance of measuring electrodes from the bottom of the tank is not specified. In case that could occur touching of the electrodes with the bottom of the tank, it is necessary that the electrode was fixedly attached to the tank bottom (the connection may be conductive or non-conductive).

For correct measurement it is important to avoid installation in the high neck. For short neck are recommended dimensional parameters:

$a \leq b$   
 $b \geq 50$  mm  
 $a$  – Neck height  
 $b$  – Neck width

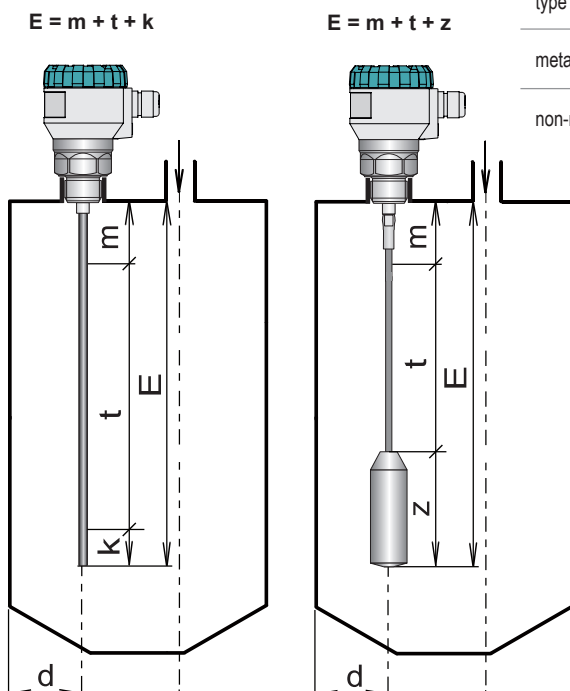

type of wall	d (without ref. tube)	d (with ref. tube)
metal	$\geq 300$ mm	any distance
non-metal	$\geq 500$ mm	any distance

E – The length of rope electrode  
 t – Measuring range  
 m – Dead zone on the beginning of electrode  
 k – Dead zone on the end of electrode  
 z – The length of weight (110 mm)  
 d – The distance from the tank wall (see Table)

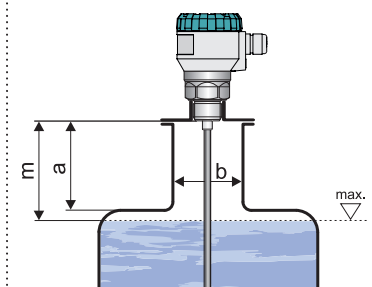

**!** If you can not eliminate all interference, which could affect the measurement of level, it is recommended to use the procedure "TEACHING" (see Instruction manual). This procedure sets the level meter to mode, which suppresses false reflections.

valid for:  
 all types

valid for:  
 all types  
 except GRLM-70\_-20

It is necessary to install the level meter so that the bin level cannot interfere with the dead zone when filled up to the maximum or deplete to the minimum. If the measured level interferes with the dead zone, the level meter will not work properly.

The size of the dead zone is affected by the set measurement sensitivity. The minimum distances to the medium (dead zones) are presented in the tables below.

measurement sensitivity	m	k (rod electrode)	k (rope electrode)
low, medium, user (1 - 4)	100 mm	0 mm	110 mm
high, user (5)	150 mm	50 mm	110 mm
user (6, 7)	200 mm	50 mm	110 mm
user (8)	250 mm	50 mm	110 mm

valid for:  
all types

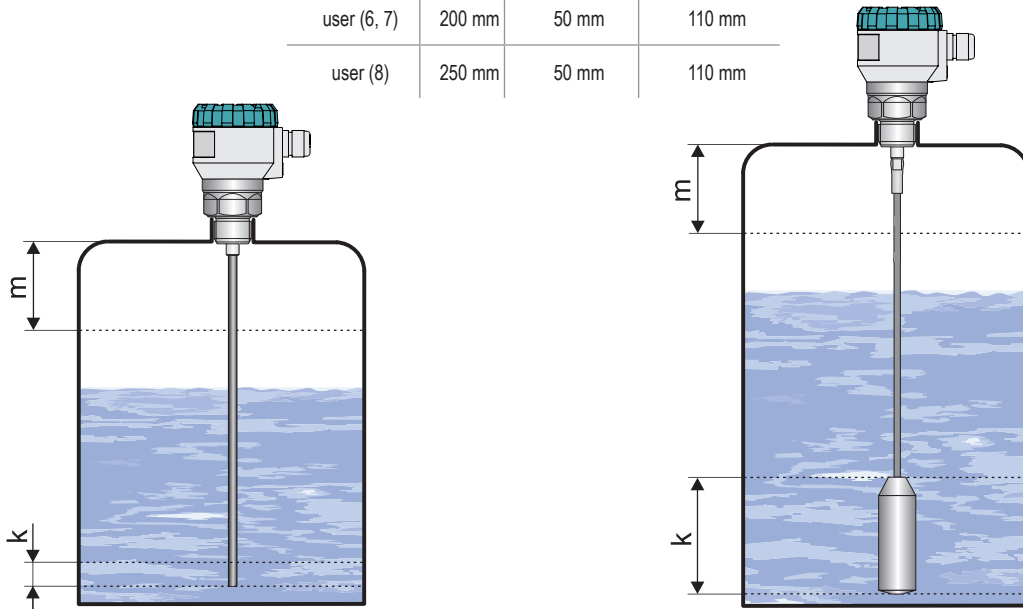

The end of the socket or the welding flange must not have an extension into the tank.

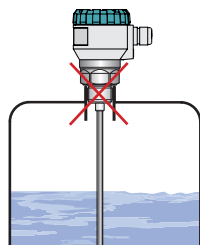

WRONG

valid for:  
all types  
except GRLM-70\_-20

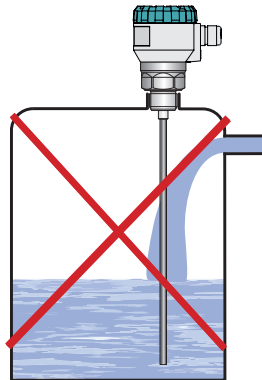

WRONG

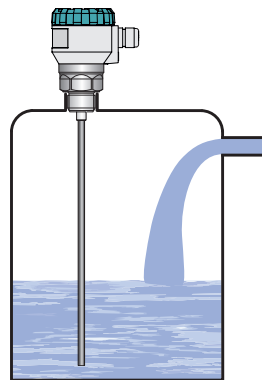

CORRECT

Nedoporučujeme instalovat hladinomer v, nebo nad místem plnění. Může docházet k ovlivnění měření vtékajícím médiem a nikoliv k měření hladiny materiálu.

valid for:  
all types

For level meter installation in **non-conductive tanks** it is necessary to use a metal sheet (diameter greater than 200 mm) beneath the process fitting when screwing it in. Make sure that the plate has direct contact with the process fitting.

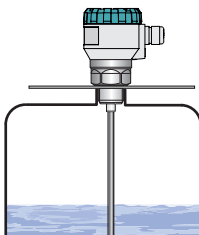

valid for:  
all types  
except GRLM-70\_-20

For installation of the level meter on a concrete roof the diameter  $b$  of the hole must be greater than the thickness  $a$  of the concrete.

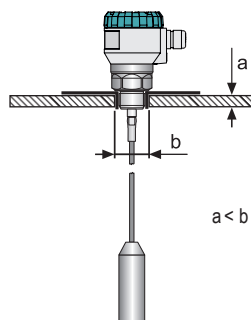

$a < b$

If the thickness  $a$  of the concrete is greater than the diameter  $b$  of the hole, install the level meter in a recess.

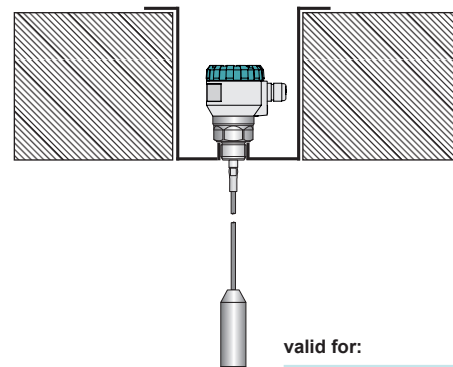

valid for:  
GRLM-70\_-30, 32, 33

It is determined **protective zone** along the electrode of radius **300 mm**. The level meter is recommended to install the tank so that the items placed inside the tank (ladders, various partitions, mixers, etc.) does not intervene into the protective zone.

If still these **objects intervene into the protective zone** of the level meter, it is necessary to create a map of false reflections by activating the "TEACHING". In case of installed mixers, it is **necessary** to position the mixers near the level meter (turning the mixer blade to the proximity of the electrode). **Items inside the tank must not be from the electrode distance of less than 100 mm**, because a interference of electromagnetic field is very strong in this zone and "TEACHING" mode can not be used.

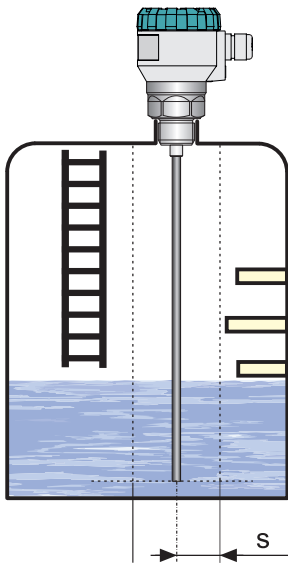

**s = 300 mm**  
s ... Radius of protective zone along the electrode level meter.

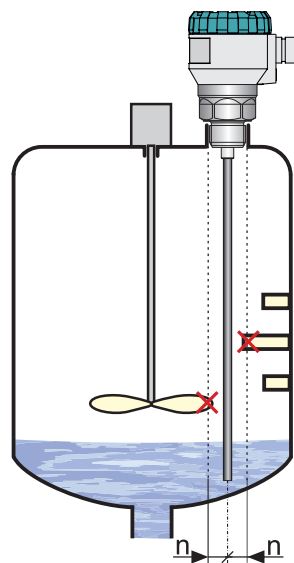

**n = 100 mm**  
n ... Minimum distance of objects from the electrode

valid for:  
all types  
except GRLM-70\_-20



If you can not eliminate all interference, which could affect the measurement of level, it is recommended to use the procedure "TEACHING" (see Instruction Manual). This procedure sets the level meter to mode, which suppresses false reflections.

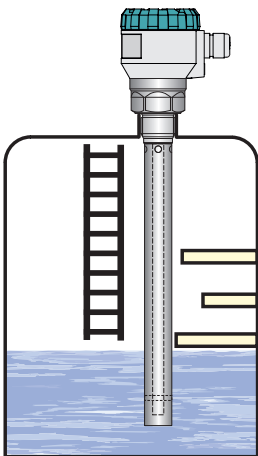

For the type of level meter **GRLM-70\_-20** electromagnetic guided wave propagates inside the reference tube. This wave is not affected by the ambient environment. So for this type of radar is not intended protective zone around the electrodes and the level meter can be used for measurements in **cramped spaces**.

valid for:  
GRLM-70\_-20

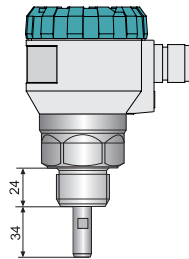

Type of level meter without electrode is supplied without an electrode. It is therefore necessary to a customer to mount his own made measuring electrode. The diameter of the electrode must be between 8-10 mm. For a connection it is necessary that on the electrode is made M8 thread. The connection procedure is given in Instruction manual.



For type GRLM-70\_-00 manufacturer is not responsible for defects which are caused by the connected measuring electrode!

valid for:  
GRLM-70\_-00

It is suitable to run the cable under a cable bushing (obliquely down in slack) to prevent penetration of humidity. Then the rain and condensing water can flow off freely. The cable bushing and connector have to be sufficiently tightened to prevent penetration of humidity.

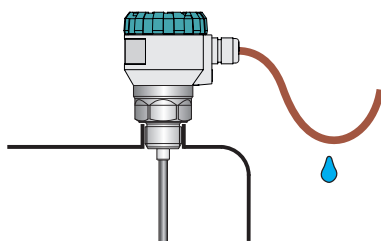

valid for:  
all types

The level meter must not be installed in places with direct solar radiation and must be protected against weather effects.

If the installation in places with direct solar radiation is inevitable, it is necessary to mount a shielding cover above the level meter.

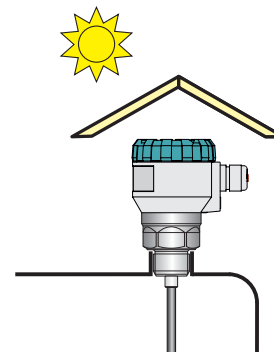

valid for:  
all types

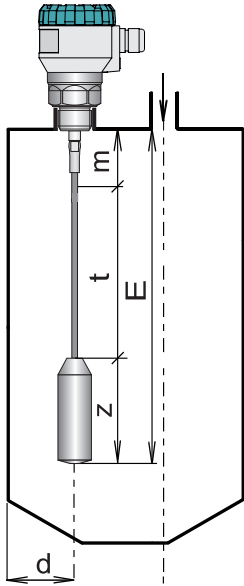

For installation of the level meter with rope electrode into deep tanks and silos the length of the electrode must be selected so that the weight will be below the minimum measured level. It must be ensured that the rope electrode could not touch the vessel wall caused by the motion of the medium. Take care does not exceed the maximum tensile load of the rope electrode. The value of the max. tensile strength is specified in chapter "Technical specifications". High loads can break the rope.

- E – The length of rope electrode
- t – Measuring range
- m – Dead zone on the beginning of electrode
- z – The length of weight (110 mm)
- d – The distance from the tank wall (min. 300 mm)

$$E = m + t + z$$

valid for:

GRLM-70\_-30, 32, 33

For installation of the level meter with rope electrode with anchorage into deep tanks and silos it is recommended to place the anchorage closer to axis of the silo than is the position of level meter. This mounting will lower the side forces of the media on the rope electrode.

In case of anchoring we recommend to preload the rope electrode by tension force of about 100 N.

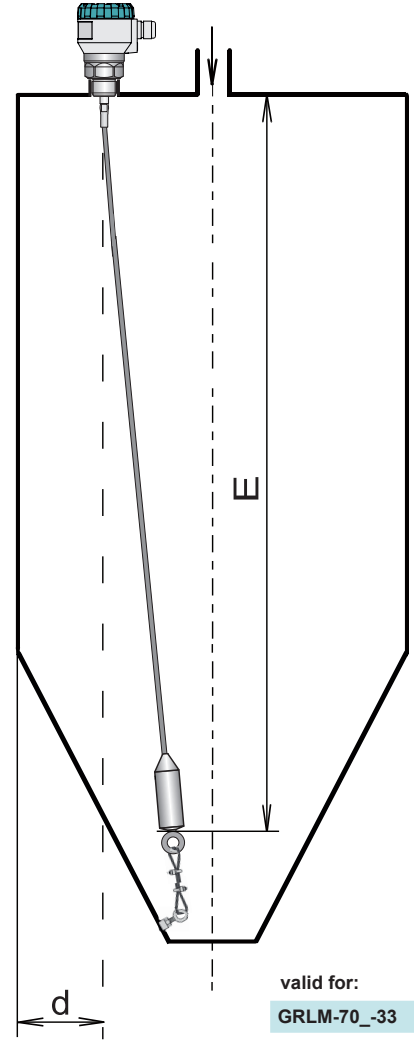

valid for:

GRLM-70\_-33

## ELECTRICAL CONNECTION

The radar level meter is designed to be connected to supply unit or to controller through a cable with the outer diameter of  $6 \div 8$  mm (recommended cross-section of cores  $0.5-0.75$  mm<sup>2</sup>) by means of bolted clips placed under display module. Connect the plus pole (+U) to the terminal "+", the minus pole to 0V to the terminal "-" and the shielding to the terminal "⏏" (only for shielded cables).

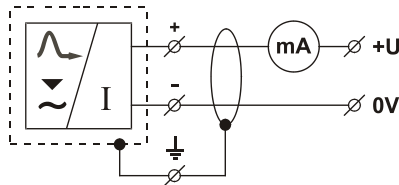

Connection diagram of the level meter

Always **disconnect** the supply voltage before connecting the level meter!

The power supply can be a stabilized voltage supply unit of 18 ... 36V DC ( $18 \div 30$  V DC for version Xi(XiT)), that is included in evaluation or display unit.

In case of strong electromagnetic interference (EMI), parallel supply cable with power lines, or when the cable length exceeds 30 m, we recommend you to use a **shielded cable**.

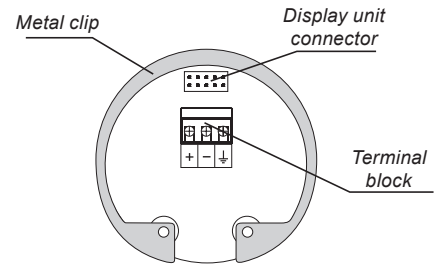

Internal view of terminal block

## LEVEL METER SETTING

Set the level meter using 3 buttons placed on the display module. All settings are accessible in the GRLM-70 set-up mode access. For detailed information please read at the instructions manual.

### OK button

- Set-up mode access
- Confirmation of selected item in the menu
- Saving of set-up data

### Up/Down button

- Move in the menu
- Change of values

### ESC button

- Cancelling of carried out changes
- Shift one level up

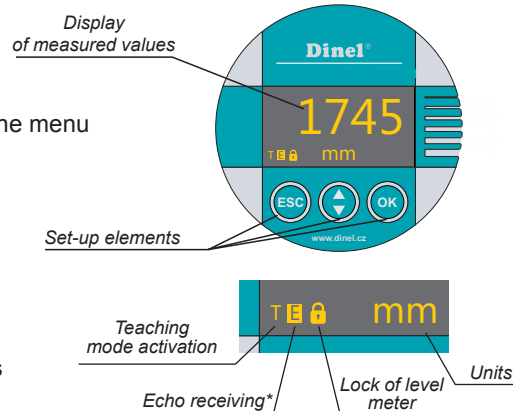

\* Slow flashing while the reflected signal (echo) is received from the measured level.



The type of level meter GRLM-70-\_-\_-\_-\_-L is supplied without a display module DM-70. To set the level meter it is required to join the display module. Once set, the display module can be disconnected and the level meter can measure without him.



## ORDER CODE

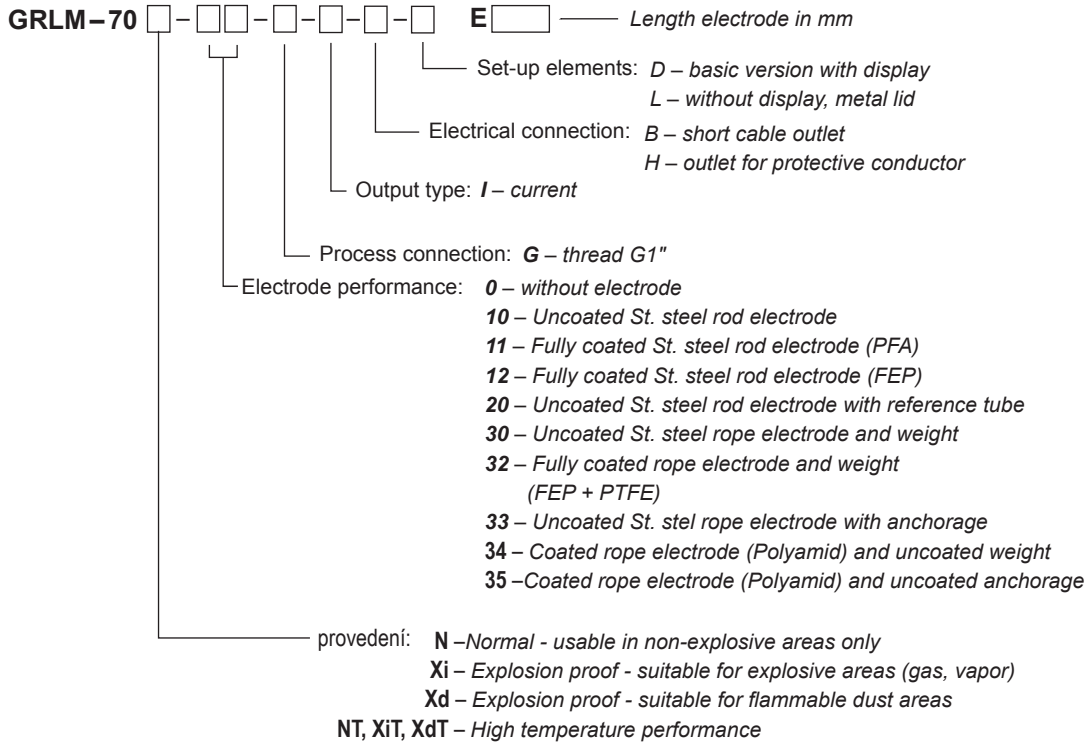

## ACCESSORIES

**Standard – included in the price of the level meter**    **Optional - for extra charge**

- 1 pc. of seal (asbestos free)
- Fixing stainless steel nuts G1"
- Steel or Stainless steel welding flange ON-G1", NN-G1"
- Other seals (PTFE, Al, etc.)

## SAFETY, PROTECTION, COMPATIBILITY AND EXPLOSION PROOF

The level meter GRLM-70 is equipped with protection against reverse polarity and output current overload. Protection against dangerous contact is secured by low safety voltage that complies with EN 33 2000-4-41.

Electromagnetic compatibility according to EN 55022/B, EN 61326/Z1 and EN 61000-4-2 to 6.

The explosion proof of GRLM-70Xi (XiT) is ensured by compliance with the following standards: EN 60079-0: 2007; EN 60079-11: 2007 and BS EN 60079-26: 2007.

Explosion proof of GRLM-70Xi (XiT) is proven by FTZÚ-AO 210 Ostrava-Radvanice: certificate No: FTZÚ 13 ATEX 0212X

### Special conditions for safe use of variant GRLM-70Xi

Level meters GRLM-70Xi (XiT) are designed for connection to intrinsically safe circuits with galvanic isolation. If you use the device without galvanic isolation (Zener barriers) it is necessary to offset a potential between the sensor and the grounding point of the barriers.



**HISPACONTROL S.L.**  
 Pº Delicias 65 Bis  
 28045 Madrid  
 Tel. 915 308 552  
[hc@hispacontrol.com](mailto:hc@hispacontrol.com)  
[www.hispacontrol.com](http://www.hispacontrol.com)