

N30U DIGITAL PANEL METER

FEATURES:

- 3-color display
- Program LPConfig
- MOD BUS
- RTC
- 21 points
- Password protection

IP65

INPUTS:

-
-
- 10..10 V
- 20..20 mA
- 60 mV

OUTPUTS:

- 0..20 mA
- 0..10 V
-
-
- 2x
- 2x
- RS 485

GALVANIC ISOLATION:

-
-
- Sup.
- Digital interface



- Measurement: temperature, resistance, standard signals.
- 3-colour display (14 mm high), programmable in 3 ranges of the measured value.
- Meter programming from keyboard or through the RS-485 interface by means of the free LPConfig program.
- 4 alarm outputs with signalling on LED diodes, working in 6 different modes.
- Conversion of any measured value into an analog signal 0/4...20 mA or 0...10 V.
- Storage of minimal and maximal values for all measured quantities.
- Supply of object transducers (option).
- 21-point individual characteristic for the measured value.

EXAMPLE OF APPLICATION

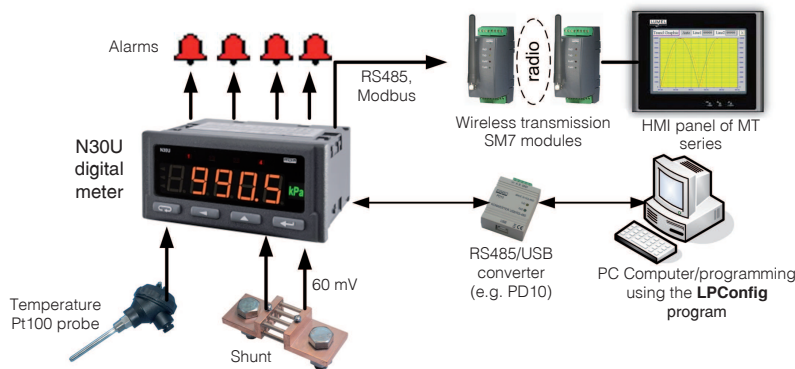

Measurement and visualization of analog standard signals: Pt100, TC, 20 mA, 60 mV, 10 V. Measured parameters are transmitted to the HMI operator panel through radio modules.

INPUT

Input kind	Maximal measuring range	Class	Additional error
Pt100	-205...855°C (-200...850°C)	0.1	Additional error of: • thermocouple cold junction temperature compensation: 0.1% of measuring range • wire resistance compensation: 0.1% of the 400 Ω range
Pt500			
Pt1000			
400 Ω	0...410 Ω (0...400 Ω)		
4000 Ω	0...4100 Ω (0...4000 Ω)		
Thermocouple of J type	-220...1210°C (-200...1200°C)		
Thermocouple of K type	-280...1382°C (-270...1300°C)		
Thermocouple of N type	-250...1310°C (-240...1200°C)		
Thermocouple of E type	-280...1010°C (-270...1000°C)		
Thermocouple of R type	-55...1775°C (-50...1770°C)		
Thermocouple of S type	-55...1775°C (-50...1770°C)		
Voltage input 0...10 V	-13...13 V (-10...10 V)	0.5 sek./ 24h	
Current input	-24...24 mA (-20...20 mA)		
Voltage input	-10...63 mV (0...60 mV)		
Current time	00.00...23.59		

OUTPUTS

Output kind	Properties	Remarks
Relay output	<ul style="list-style-type: none"> • 2 x relays, voltageless NOC contacts load-carrying capacity 250 V a.c./ 0.5 A a.c. • 2 x relays, voltageless switched contacts load-carrying capacity 250 V a.c./ 0.5 A a.c. 	
Analog output	<ul style="list-style-type: none"> • current programmable 0/4...20mA, load resistance ≤ 500 Ω • voltage programmable 0...10 V load resistance ≥ 500 Ω 	Error of analog output: 0.2% of the set range Additional error from temperature changes: 50% of the class/10K
OC output	• typu OC, passive npn, 30 V d.c./30 mA	Voltageless output
Auxiliary supply	• 24 V d.c./ 30mA	

DIGITAL INTERFACE

Interface type	transmission protocol	modes	baud rates
RS-485	MODBUS RTU	8N2, 8E1, 8O1, 8N1	4.8, 9.6, 19.2, 38.4, 57.6, 115.2 kbit/s

EXTERNAL FEATURES

Readout field	5 digit LED display - indication range -19999..99999 digit height: 14 mm	three-color display (colour changes depending on displayed value): red, green, orange
Weight	< 0.2 kg	
Dimensions	96 × 48 × 93 mm	Panel cut-out: 92 ^{+0,6} × 45 ^{+0,6} mm
Protection grade (acc. to EN 60529)	from frontal side: IP65	from rear side: IP 10

RATED OPERATING CONDITIONS

Supply voltage	85...253 V a.c. (40...400 Hz) or d.c., 20...40 V a.c. (40...400 Hz) or d.c.	
Temperature	ambient: -25...23...55°C	storage: -30...70°C
Relative humidity	25...95%	condensation inadmissible
Operating position	any	
External magnetic field	0...400 A/m	

SAFETY AND COMPATIBILITY REQUIREMENTS

Electromagnetic compatibility	Noise immunity	acc. to EN 61000-6-2
	Noise emissions	acc. to EN 61000-6-4
Isolation between circuits	basic	acc. to EN 61010-1
Pollution grade	2	
Installation category	III	
Maximal phase-to-earth operating voltage	for the supply circuit: 300 V for remaining circuits: 50 V	
Altitude above sea level	< 2000 m	

CONNECTION DIAGRAMS

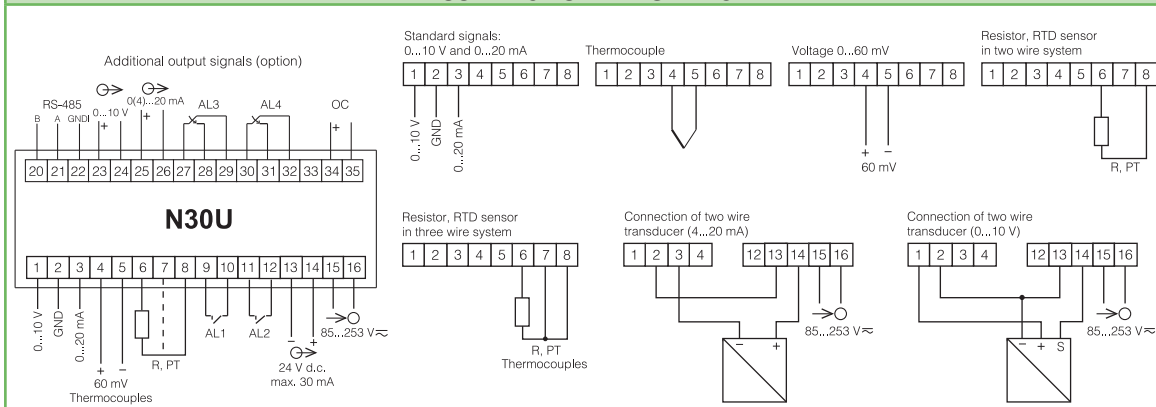

SEE ALSO:



Free LPConfig software for easy programming of LUMEL's products. Available on our website



KD7 recorder with MODBUS master protocol for recording data measured by N30U.



Shunts for measurement DC current from 5A up to 15 kA. For more details see our ANALOG METERS catalogue.

ORDERING

TABLE 1. ORDERING CODES:

N30U -	X	X	XX	XX	X	X
Supply:						
85...253 V a.c./d.c.	1					
20...40 V a.c./d.c.	2					
Additional outputs:						
lack		0				
OC output, RS-485, analog outputs		1				
OC output, RS-485, analog outputs switched-over relay outputs		2				
Unit:						
unit code acc. to the table 2			XX			
Version:						
standard				00		
custom-made*				XX		
Language:						
Polish					P	
English					E	
other*					X	
Acceptance tests:						
without extra requirements						0
with an extra quality inspection certificate						1
acc. to customer's request*						X

Order example: The code **N30U - 1 0 26 00 E 0** means
N30U - programmable N30U digital panel meter
1 - supply: 85...253 V a.c./d.c.
0 - lack of additional outputs
26 - unit "°C" acc. to tabel 2
00 - standard option
E - English language
0 - without extra requirements

TABLE 2. CODES OF HIGHLIGHTED UNIT:

Code	Unit	Code	Unit	Code	Unit
00	lack of unit	20	kVAh	40	pcs
01	V	21	MVAh	41	imp
02	A	22	Hz	42	rps
03	mV	23	kHz	43	m/s
04	kV	24	Ω	44	l/s
05	mA	25	kΩ	45	turns/min
06	kA	26	°C	46	rpm
07	W	27	°F	47	mm/min
08	kW	28	K	48	m/min
09	MW	29	%	49	l/min
10	var	30	%RH	50	m³/min
11	kvar	31	pH	51	pcs/h
12	Mvar	32	kg	52	m/h
13	VA	33	bar	53	km/h
14	kVA	34	m	54	m³/h
15	MVA	35	l	55	kg/h
16	kWh	36	s	56	l/h
17	MWh	37	h		
18	kvarh	38	m³	XX	on order*
19	Mvarh	39	turns		

* - after agreeing with the manufacturer



HISPACONTROL S.L. ☐
Paseo Delicias 65 Bis ☐
28045 Madrid ☐
 ☐
Tel. 915.308.552 ☐
Fax. 914.673.170 ☐
Email. ☐
hc@hispacontrol.com ☐
Web. ☐
www.hispacontrol.com