

Sprague®

PowerStar™ 4



Gas Boosters



Air Amplifiers

HISPACONTROL^{HC}

INSTRUMENTACION INDUSTRIAL

HISPACONTROL S.L.

Paseo Delicias 65 Bis, 1D

28045 Madrid

Tel. 915 308 552

hc@hispacontrol.com

www.hispacontrol.com



Sprague® Products

Division of Curtiss-Wright Flow Control Corporation



Gas Boosters and Systems

- Works off compressed air supplies
- Operates quietly
- Features mechanical separation between air drive and boosted gas
- Compatible with most gases

The PowerStar™4B gas booster is a reciprocating, single or double or dual stage air operated unit. It uses an air-piloted unbalanced type air directional valve to cycle the booster.



The Principles of Operation

The PowerStar™4B gas booster operates on the differential piston area principle. A large area piston, driven at low air pressures, drives a small area compression piston which converts input gas to higher pressure. The output gas or discharge pressure is determined by the ratio between the area of the drive piston, the operating air pressure and the available precharge pressure supply.

The function of the precharge pressure is to charge the high pressure cylinder inside the booster with gas, reducing the time needed to reach higher pressures. In double-ended gas boosters, the precharge gas adds power to the compression stroke.

The Actual Operation

The PowerStar™4B gas booster works rapidly at first, then slows and stops at a pressure balance. The booster holds the pressure balance indefinitely, assuming no leakage. When a pressure imbalance occurs, the booster automatically restarts and restores the pressure balance. During operation, exhaust air from the air drive section cools the high pressure boosting chamber.

The Gas Booster in Action

Whether you use gas above normal cylinder pressure or require continuous high pressure and want to get the most out of the cylinder's gas supply, the PowerStar™4B Series is for you! It assures the optimum use of commercially-bottled gas. Some units draw a vacuum.

The applications for this versatile gas booster are endless and include:

Aviation and Aerospace

- Static and dynamic testing of valves and components at overhaul facilities
- Inflating high pressure aircraft tires
- Instrument calibration

Automotive

- Air bag testing
- Gas spring charging systems for die and mold manufacturers
- Accumulator charging

Petrochemical

- Heel recovery from cylinders for gas transfer
- Gas blanketing

Diving

- Filling air tanks from larger cylinders
- Testing air pressure regulators
- Gas mixing

Fire Protection

- Filling breathing air cylinders
- Mobile filling stations for firefighters
- Halon and CO₂ charging

Fluid Power

- Testing hoses and valves
- Testing and calibrating gas components
- Accumulator charging

Machine Tools

- Power clamping
- Quick die change

Plastics

- Ejecting parts from molds
- Gas injection

Packaging

- Injecting nitrogen into aerosol cans

TABLE 1 GAS BOOSTER PERFORMANCE

Approximate performance based on a maximum air consumption of **50 SCFM**

Gas Booster Model Number	Inlet Port Precharge Pressure psi	Outlet Port Pressure (w/100 psi driving air)	DISCHARGE CAPACITY-Standard Cubic Inches per Minute (SCIM)											
			DISCHARGE PRESSURE-psi											
			200	400	600	800	1000	2000	3000	4000	5000	6000	7000	8000
P4BS010	100	1000	4593	4176	3854	3533								
P4BS010	200	1000	8598	7815	7215	6614								
P4BS034	400	3400			4388	4342	4296	3683	3314					
P4BS034	500	3400			5447	5390	5332	4571	4114					
P4BS050	400	5000			2747	2709	2517	2382	2248	2171				
P4BS050	500	5000			3410	3362	3124	2957	2790	2694				
P4BS080	600	8000							2353	2186	2002	1919	1852	
P4BS080	1000	8000							3883	3608	3305	3167	3057	
S010P4BS010	50	1050	4405	4004	3696	3388								
S010P4BS010	100	1100	7808	7099	6552	6006								
S010P4BS010	200	1200	14617	13286	12266	11244								
S034P4BS034	300	3700			5661	5602	5542	4752	4276					
S034P4BS034	400	3800			7460	7381	7303	6261	5634					
S034P4BS034	500	3900			9260	9163	9064	7771	6994					
S050P4BS050	400	5400			4670	4605	4279	4049	3822	3691	2117			
S050P4BS050	500	5500			5797	5715	5311	5027	4743	4580	2627			
S080P4BS080	600	8600							4000	3716	3403	3262	3148	1889
S010P4BS034	100	3840			3109	3109	3053	2855	2533					
S010P4BS050	100	5600			3109	3109	3053	2855	2691	2533	2329			
S010P4BS080	100	8900			3109	3081	3053	2940	2883	2770	2657	2544	2431	2318

TABLE 2 GAS BOOSTER PERFORMANCE

Approximate performance based on a maximum air consumption of **50 SCFM**

Gas Booster Model Number	Inlet Port Precharge Pressure psi	Outlet Port Pressure (w/100 psi driving air)	Time required in minutes to fill a 100 cubic inch air receiver to listed discharge											
			DISCHARGE PRESSURE-psi											
			200	400	600	800	1000	2000	3000	4000	5000	6000	7000	8000
P4BS010	100	1000		0.4	0.8	1.2	1.7							
P4BS010	200	1000		0.2	0.4	0.7	0.9							
P4BS034	400	3400				0.8	1.1	3.0	5.3					
P4BS034	500	3400				0.4	0.9	2.5	4.3					
P4BS050	400	5000				1.0	1.5	4.4	7.6	11.1	15.1			
P4BS050	500	5000				0.6	1.0	3.3	5.9	8.7	11.9			
P4BS080	600	8000							6.9	10.0	14.7	18.8	23.1	27.9
P4BS080	1000	8000							3.5	5.4	8.1	10.6	13.1	16.0
S010P4BS010	50	1050		0.5	0.9	1.4	1.9							
S010P4BS010	100	1100		0.3	0.5	0.7	1.0							
S010P4BS010	200	1200		0.1	0.2	0.3	0.5							
S034P4BS034	300	3700				0.6	0.9	2.4	4.1	10.0				
S034P4BS034	400	3800				0.4	0.6	1.7	3.0	7.4				
S034P4BS034	500	3900				0.2	0.4	1.3	2.4	5.8				
S050P4BS050	400	5400				0.6	0.9	2.6	4.4	6.5	8.9			
S050P4BS050	500	5500				0.4	0.6	2.0	3.4	5.1	7.0			
S080P4BS080	600	8600							4.1	5.9	8.7	11.1	13.6	16.4
S080P4BS080	1000	9000							2.5	3.6	5.2	6.7	8.2	10.0
S010P4BS034	100	3840				1.5	2.0	4.4	7.2	11.4				
S010P4BS050	100	5600				1.5	2.0	4.4	7.2	10.0	13.7			
S010P4BS080	100	8900				1.5	2.0	4.3	6.7	9.4	12.3	15.4	18.9	22.6

Gas Boosters and Systems

MODELS

Single Ended Ratio Non Separated	Double Ended Ratio Non Separated	Dual Ratio Non Separated	Single Ended Ratio Separated	Double Ended Ratio Separated	Dual Ratio Separated
P4B010	010P4B010	010P4B034	P4BS010	S010P4BS010	S010P4BS034
P4B034	034P4B034	010P4B050	P4BS034	S034P4BS034	S010P4BS050
P4B050	050P4B050		P4BS050	S050P4BS050	S010P4BS080
			P4BS080	S080P4BS080	

PORTING

Gas Booster Model	Inlet Ports Gas	Outlet Ports Gas	Inlet Ports Air	Shipping Weight Approx.
All single-ended	3/8" NPT	1/4" NPT	3/8" NPT	20 lbs.
All double-ended	3/8" NPT	1/4" NPT	3/8" NPT	25 lbs.

DIMENSIONS

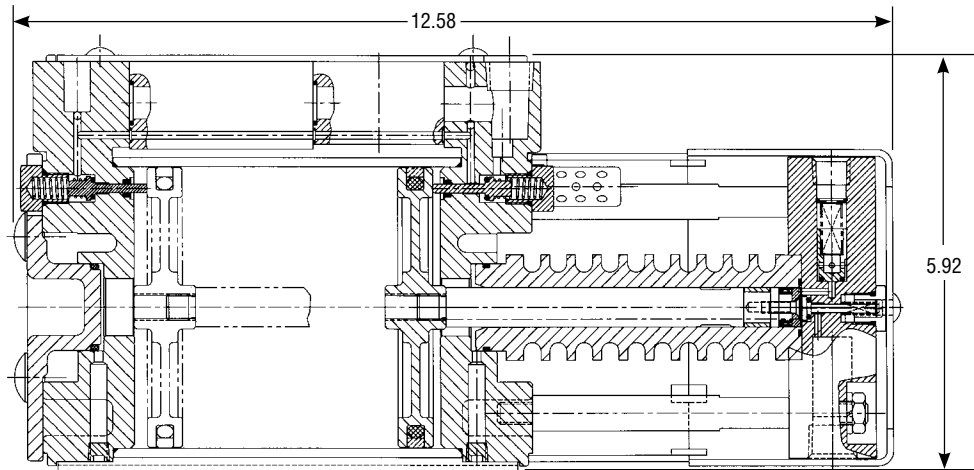

Single-ended Booster

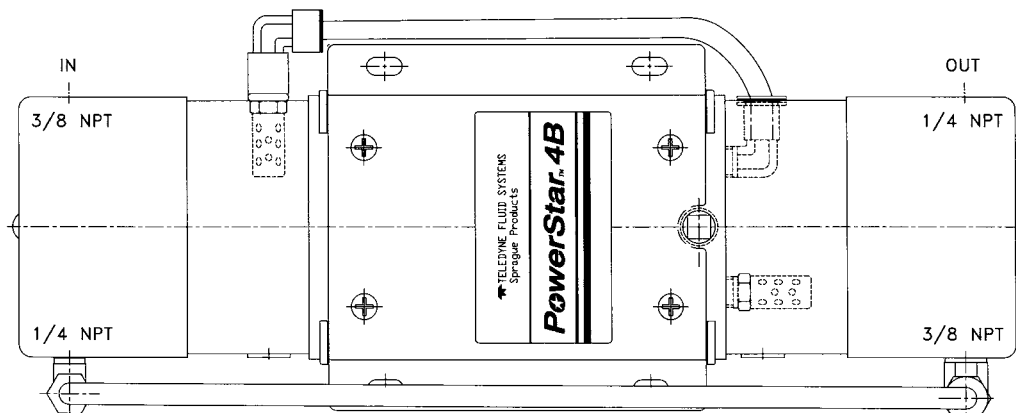
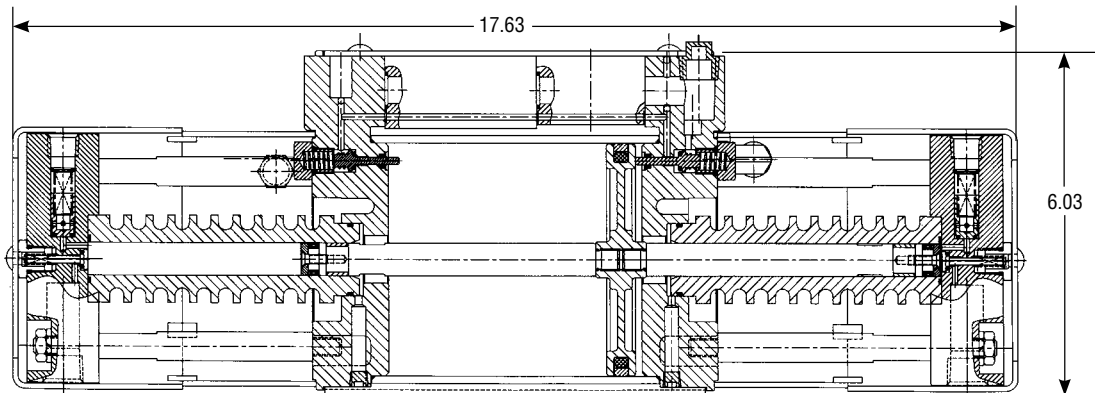

Dual Ratio Booster

Breathable Air Booster and Oxygen Service Booster



Oxygen service booster P/N 93992-034-OX

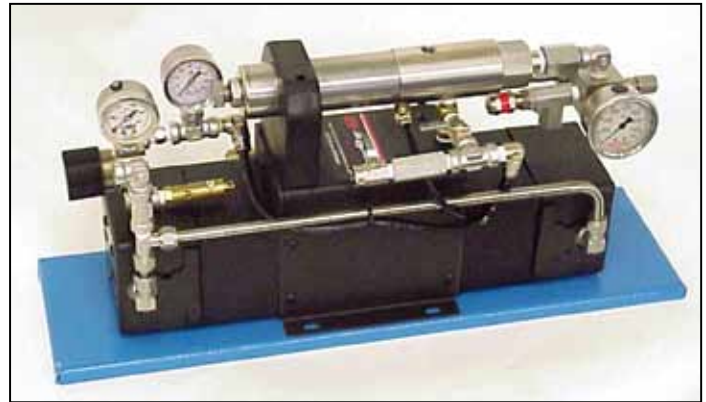

Breathable air booster HPU-1200

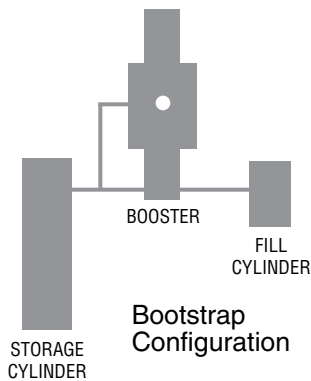

Bootstrap Configuration - Number of Fills

Storage cylinder Pressure/Volume psig/scf	SCBA cylinder to be filled Pressure/Volume psig/scf				
	2216/45	4500/45	4500/88	2250/72	3000/80
2400/260	3.2	1.6	0.8	2.2	1.2
4500/444	8.1*	4.5**	2.3	5.0	3.6
5000/450	9.0	5.1	2.6	5.6	3.9
6000/509	11.0	6.7	3.4	6.9	4.6

*represents an increase in total fills from 6.5 to 8.1 when using a booster.

**represents an increase in total fills from 0 to 4.5 when using a booster.

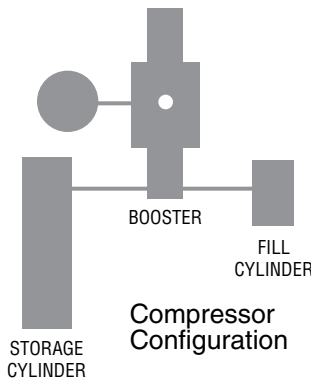

Compressor Configuration - Number of Fills

Storage cylinder Pressure/Volume psig/scf	SCBA cylinder to be filled Pressure/Volume psig/scf				
	2216/45	4500/45	4500/88	2250/72	3000/80
2400/260	6.2	5.5	2.8	3.9	3.4
4500/444	12.0*	10.2**	5.2	7.5	6.4
5000/450	12.4	10.3	5.3	7.6	6.5
6000/509	14.0	11.8	6.0	8.8	7.3

*represents an increase in total fills from 6.5 to 12.0 when using a booster.

**represents an increase in total fills from 0 to 10.2 when using a booster.

Fill Times (Minutes)

Inlet Pressure psig	SCBA cylinder to be filled Pressure/Volume psig/scf				
	2216/45	4500/45	4500/88	2250/72	3000/80
500	28.5	32.9	64.2	45.8	54.7
1000	10.3	14.6	28.5	16.6	22.2
1500	4.0	8.4	16.4	6.7	11.1
2000	0.9	5.2	10.3	1.7	5.6

Notes:

- The booster will operate using a small compressor that is continuously rated from 1.5 HP/6 SCFM to 10 HP/50 SCFM at 100 psi.
- Fills and times are based on empirical and laboratory data, and can be adversely affected by plumbing configuration, leaks, cylinder capacities, etc.
- All tables are based on 100 psi drive air pressure, 500 psi minimum inlet pressure, 500 psi initial fill cylinder pressure, average air motor consumption of 13 SCFM, and using the PowerStar S050P4B050 booster.

Advanced Air Driven Air Amplifier

Performance Chart: AA4P4AA4 Double-ended Air Amplifier

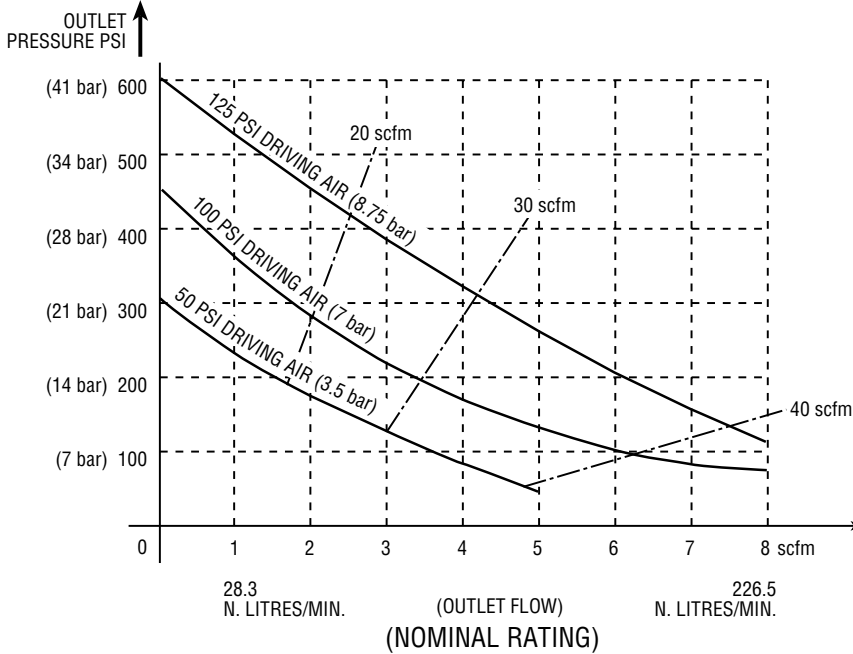

Solid lines indicate approximate flows at various driving air pressure. Dotted lines indicate air consumption in scfm.

All air driven air amplifiers will operate on low air volumes as long as the supply is sufficient to overcome minor internal leakage and operate the air selector valve in the air motor section.

Note: most air compressors produce 4-5 scfm of compressed air per horsepower at 100 psi. As an example, with 100 psi (6.8 bar) driving air, the air amplifier consumes 30 scfm at an operating pressure of 200 psi (14 bar) and produces an output flow of 3.5 scfm.

Note: for applications above 450 psi (31.5 bar), consult factory.

Note: stall conditions on double ended units are best achieved by regulating air motor pressure 10% lower than precharge.

Nominal Dimensions: Single-ended and Double-ended

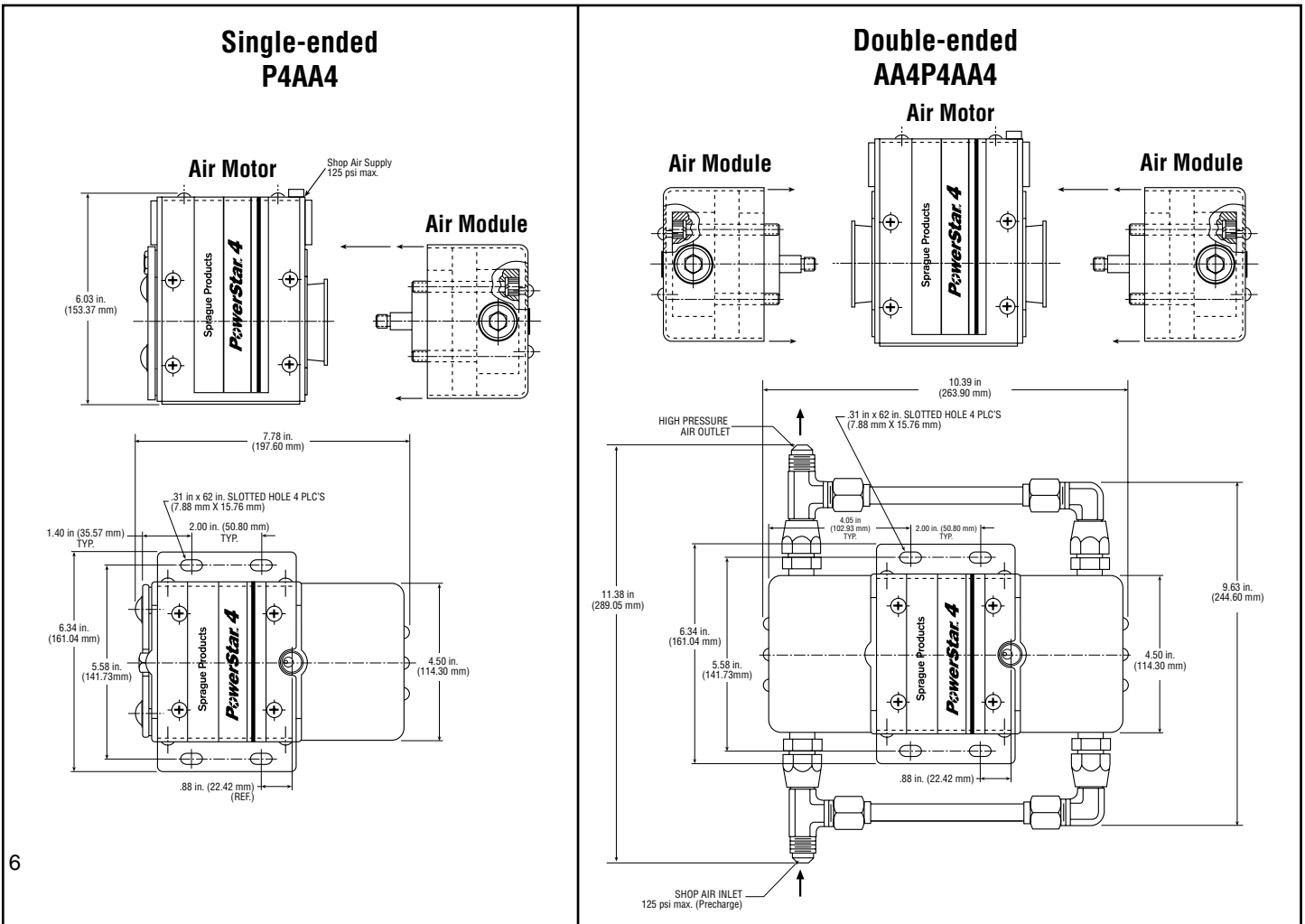

How the Air Amplifier Works

The PowerStar 4 air amplifier develops high output pressures by applying the principle of differential areas. It features a large area air motor piston (air driven at low 10-125 psi pressures) that drives a small area air piston that amplifies the incoming air pressure.

Air output pressure is determined by the ratio between the area of the air motor piston, the area of the small high pressure piston and the applied driving air pressure. The relationship of

the air motor piston to the small area piston is referred to as the Air Amplifier Ratio.

In operation, the AA4P4AA4 model using 125 psi input air pressure (at the air motor), can produce a maximum air output pressure of 600 psi (limited to 500 psi in the P4AA4PCT and AA4P4AA4PCT models with an ASME tank rated at 500 psi). At 100 psi input air pressure, the air amplifier can produce an output air pressure of 450 psi; at 50 psi input pressure, it can produce an output air pressure of 300 psi.

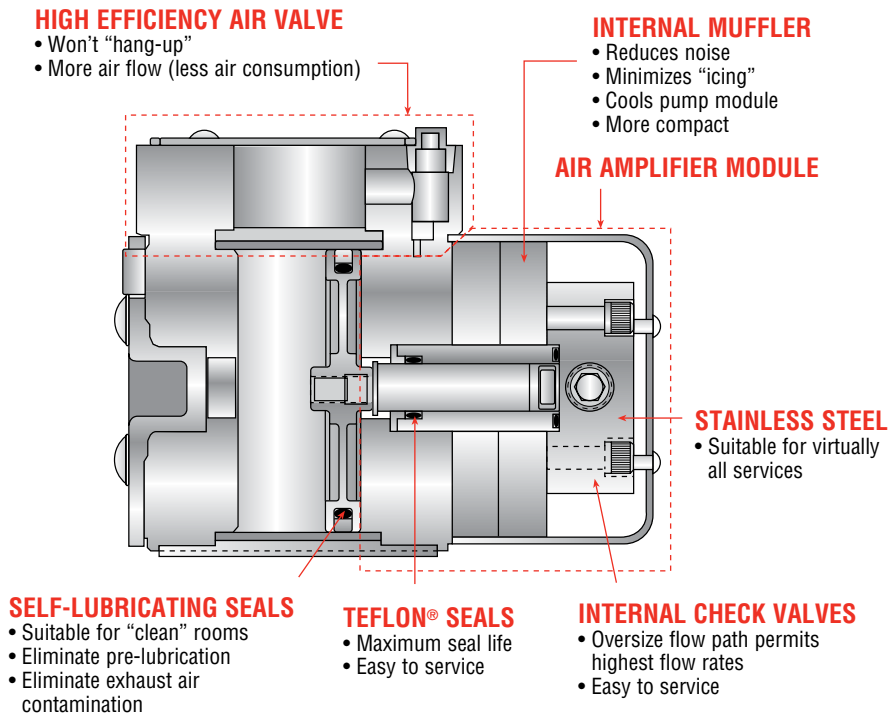

Weights & Porting

Air Amplifier Model No.	Inlet Port Air Module	Outlet Port Air Module	Inlet Port Air Motor	Approx. Shipping Weight
P4AA4	1/2 _≤ NPTF	3/8 _≤ NPTF	3/8 _≤ NPTF	16 lbs (7.26 Kg)
AA4P4AA4	-8, 37 deg. Male flare fittings	3/8 _≤ NPTF	3/8 _≤ NPTF	21 lbs (9.53 Kg)
P4AA4PCT	1/2 _≤ NPTF	3/8 _≤ NPTF	3/8 _≤ NPTF	80 lbs (36.3 Kg)
AA4P4AA4PCT	1/2 _≤ NPTF	3/8 _≤ NPTF	3/8 _≤ NPTF	85 lbs (38.6 Kg)

Typical 5 gallon ASME Tank

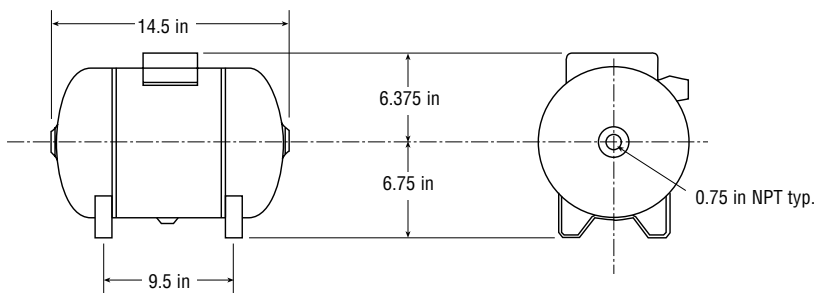

Order Information

Components	Description
P4	Air Motor Module
AA4	Air Amplifier Module
P4AA4	Single Air Amplifier (Assembled)
AA4P4AA4	Double Air Amplifier (Assembled with plumbed inlets & outlets)
A	Air Control Kit (Filter, regulator, gauge, fittings)
Systems	Description
P4AA4PCT	Single Air Amplifier, Complete System (5 gal. ASME tank, 500 psi rating, ASME relief valve, gauge, shut-off valve)
AA4P4AA4PCT	Double Air Amplifier, Complete System (5 gal. ASME tank, 500 psi rating, ASME relief valve, gauge, shut-off valve)

Also from Sprague® Products



Hydraulic Pumps, Gas Boosters,
Power Units, Specialty Valves
& Accessories



Advanced Air Driven
Power Units



Advanced Air Driven
Power Units



Nitrogen Gas Booster
Assembly



PowerStar™ 4 Advanced
Air Driven Pump Systems



Sprague® Products

Division of Curtiss-Wright Flow Control Corporation