

DM650PM FIELD/WALL MOUNTED PRESSURE DISPLAY

- > **UP TO 100 bar PRESSURE/TEMPERATURE DISPLAY WITH SCALING/LINEARISATION**

- > **BATTERY POWERED**

- > **ALARM RELAY, MAX/MIN INFORMATION**

- > **USER-SET DISPLAY MESSAGING**

- > **5000 POINT DATA LOGGER (USB or COMPATIBLE ANDROID DEVICE)**

> INTRODUCTION

The DM650PM battery powered indicator accepts gauge pressure inputs up to 100 bar and displays the sensor pressure in bar, PSI or the user's engineering unit on a 6-digit LCD display. The instrument offers an advanced display mode allowing the user to also display one or two (1 to 32) character messages. Additional to the messages, the user may select an alert-event to occur when the pressure is within a band. A change-over relay can be used together with the messaging and alerts to provide switching at user-set points. In addition to this, on-board datalogging is also available to record process details at up to 5000 points. Force calculations (Ram force for example) can also be performed and displayed.

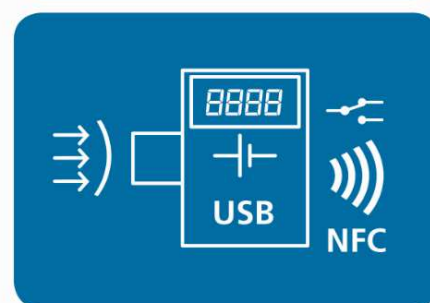

> FEATURE HIGHLIGHTS

RELAY

The instrument is equipped with single volt-free changeover-type relay. The user may select one of several actions, including deviation operation, with fully adjustable set point and dead-band. An option is provided to trigger an alert-event when a relay contact is on.

DATA LOGGING FUNCTION

DM650PM also provides a powerful data logging function. The log points can be set up to 5000 points; each point is time and date-stamped together with process value, and relay state information.

The log rate is selectable in steps. The start of log can be delayed if required. Either fixed or rolling logs may be performed.

Two methods of reading the log are available. The USB configuration reads the log and allows the user to save to a text file for export to other programmes. The NFC android interface allows data transfer to compatible android phones or tablets, by using the downloadable App, the data can be graphed and forwarded by email, Bluetooth etc. The NFC interface is also capable of starting a new log with different log period and modes.

CALIBRATION/USER-LINEARISATION

5-point calibration can be applied using the USBSpeedLink software.

As well as straight line interpolation, up to 22 points (x,y) of user-linearisation are available for creating custom curves and corrections.

REAL-TIME CLOCK

Date and time can also be displayed with the input pressure. The real-time clock is used to record the data logged points.

DM650PM FIELD/WALL MOUNTED PRESSURE DISPLAY

INPUT PRESSURE		SPECIFICATIONS @20°C
Type	Range	Accuracy/stability
Sealed gauge *1	(-0.5 to 0.5) bar (0 to 3) bar (-1 to 9) bar (0 to 30) bar (0 to 100) bar	±0.5% of full scale between (0 to 50) °C *2 ±0.7% of full scale between (-10 to 80) °C *2
	Other ranges	Contact sales@status.co.uk
Overpressure	Range up to 100 bar	4 x maximum range (maximum 350 bar)
Thermal drift	(-10 to 80) °C compensated	
*1 Shows zero bar at 1.0 bar absolute		
*2 Total error band: Maximum deviation within specified pressure and operating temperature range		

INPUT Temperature		SPECIFICATIONS @20°C
Type	Range	Accuracy/stability
Medium temperature	(-40 to 110)°C	Typically, ±2.0°C

DISPLAY	
Type/options/function	Description
Display height	7.9 mm non-backlit
Display information options Some information is displayed scrolling.	6 digits 14 segment input value plus "Warning", "Transmit", "NFC", "USB", "Log", icons, 8 segment log volume indicators. Maximum, minimum. Date and time. Custom messages for visual alarms/information. Relay condition.
High intensity LED	Alarm and warning options

RELAY	
Type/options/function	Description
Independent relay	Single pole change-over (common, N/o, N/c)
Rating	48 VDC maximum @ 1 A (5 mA minimum) 28 VAC RMS maximum @ 1 A

USB CONFIGURATION USER INTERFACE		
Type/options/function	Description	Notes
Configuration hardware	USB Mini B port	Cable not included
Configuration software	USBSpeedLink	Download www.status.co.uk
Operating system	Microsoft Windows	Win 7 or later
Sensor configuration	User calibration Off-set in Bar	Up to 5 points Applied by button action
Display configuration	Display mode Pressure units Custom units	Basic with advanced options °C or °F Bar, PS I, mBar, Pa, KPa, MPa Kgf/m ² , Kgf/cm ² , Kgf/mm ² Atm, custom units (any) With 22-point linearization
Pre-set sensor to setpoint	Locks input value to setpoint	For diagnostics
LED alert (advanced mode)	Eight user adjustable pressure bands	Alert LED flash
Warning symbol	Out of range Low battery level	Warning symbol will flash on LCD display

DM650PM FIELD/WALL MOUNTED PRESSURE DISPLAY

USB CONFIGURATION USER INTERFACE (Continued)		
Basic display mode	Update rate Display variable options Temperature units Alert LED	1 s, 5 s Input, input + units, input + units + temperature °C or °F
Advanced display mode *1	Display variable (see basic mode) with messaging options	
Battery monitor	Alert LED plus message	Relay option link in software
Logger	Set device passkey number Clear, start new log	Device passkey is used to protect the NFC interface.
Other device options	Synchronise clock Write tag, contact address Read, reset maximum and minimum input values Latitude longitude settings	
Relay control	Name(s) Action Setpoint Dead band Latch	10 characters High, low, band, low battery, on, off In engineering units In engineering units On, off
Live data	Read sensor pressure Read displayed value Read sensor temperature Relay 1 state. Relay 2 state Time and date	bar Selected engineering unit °C
*1 Only use advanced display above -5°C ambient temperature, below use basic display		

USB LOGGER USER INTERFACE		
Type/options/function	Description	Notes
Logger hardware	USB Mini B port	Cable not included
Logger software	USBLogLink	Download www.status.co.uk
Operating system	Microsoft Windows	Win 7 or later
Logger	Start/set log parameters	Interval, rate, (delay) start, number of points, rolling or fixed log
	Read log parameters	
	Stop, start new log Synchronise device clock Reset maximum and minimum Synchronise, read clock	
	View log data, graph log data	Save data to CSV file

NFC ENABLED ANDROID DEVICE REQUIREMENTS	
Tag Type	NFC Forum Tag Type 4 (max capacity 65536 Bytes)
RF Interface	ISO/IEC 14443 Type B Compliant (13.56 MHz)
Android device	Compatibility to read NFC Tag type 4 to full capacity 65536 bytes
Note: If the android device cannot read full bytes the maximum number of log points will be reduced.	

DM650PM FIELD/WALL MOUNTED PRESSURE DISPLAY

NFC LOGGER USER INTERFACE ANDROID		
Type/options/function	Description	Notes
Logger software	NFCLogLink	@ Google Play Store
Operating system	Android V4.4 Kitkat or later	NFC enabled
Logger	Start, set log parameters	Interval, rate, (delay) start, number of points, rolling or fixed log
	Read log parameters	
	Stop, start new log	
	Synchronise, read clock	
	Reset maximum and minimum	
View log data, graph log data	Save data to text file	
Transfer data via email etc.	Standard Android functions	

GENERAL	
Function	Description
Update rate	1 or 5 seconds
Relay response time	< 10 seconds
Battery	1 x (AA 3.6 V lithium)
Battery life	1 year minimum @20°C (longer depending on options selected)
Clock accuracy	±2 seconds per month typically

ENVIRONMENTAL	
Function	Description
Ambient housing temperature	Operating/storage (-30 to 70)°C
Ambient sensor temperature	Operating (-40 to 110)°C
Ambient humidity	Operating/storage (10 to 90) %RH non-condensing
Protection	IP67, cable entry must be sealed to IP67
USB configuration ambient	(10 to 30)°C

CONNECTIONS	
Sensor to process	¼ inch BSP male with adaptor options (see accessories)
Output relay	Two-part screw connectors
USB connection	USB mini B port

MECHANICAL	
Enclosure (case)	ABS, grey base, grey clamp ring, side or base mount options
Display cover	Polycarbonate, clear
Case entry	1 x M20 female thread, blanking plug supplied
Front bezel diameter	65 mm
Weight (approximate)	250 g
Material in contact with media	Stainless steel 316L
O-ring	Viton

APPROVALS	
EMC	BS EN 61326
Ingress protection	BS EN 60529
RoHS	Directive 2011/65/EU

DM650PM FIELD/WALL MOUNTED PRESSURE DISPLAY

ORDER CODE	DM650PM		
Case	Body Type	Input range options in sealed gauge bar	
Side mounted can be wall mounted	/B	/option	B = (-0.5 to 0.5) C = (0 to 3) D = (0 to 30) E = (-1 to 9)
Base mounted	/C	/option	G = (0 to 100)
Example: Side mounted, (0 to 30) bar, M20 cable entry		Please state required cable entry (Default M16 with blanking plug) M16, M20, M24, ½ inch BSP, ½ inch NPT	
DM650PM	/B	/D	/M20

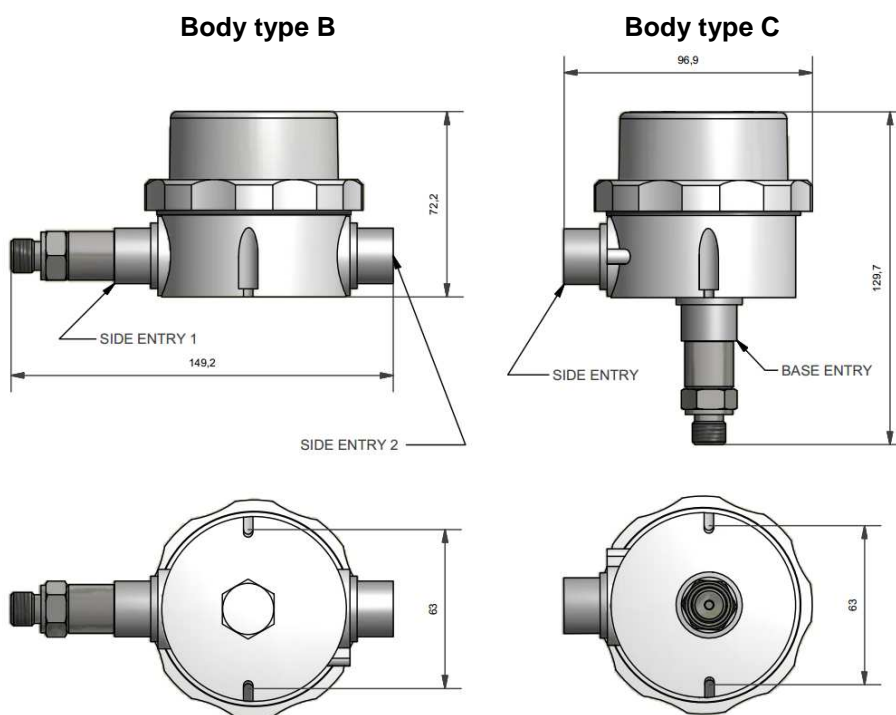

ACCESSORIES	
Swivel adaptor ¼ BSPP	SA14BSP
Swivel adaptor ½ BSPP	SA12BSP
Swivel adaptor ¼ NPT	SA14NPT
Swivel adaptor ½ NPT	SA12NPT
Swivel adaptor other options available	
Hygienic fittings available	
Configuration software	USBSpeedLink free of charge
USB logging software	USBLogLink free of charge
NFC logging software	NFCLogLink free of charge refer to Google Play Store
USB lead	USB lead, part number 42-200-0001-01
Battery 3.6 V lithium	

To maintain full accuracy annual calibration is required
 The data in this document is subject to change. Status Instruments assumes no responsibility for errors